

PROJECT NAME: CS-00011205_KARAKURI STACKING.asm	
DESIGN BY:	EdderAcuñaMojón/13/2023
DRAWING BY:	MSANDOVAL 6/4/2023
CUSTOMER APPROVAL	

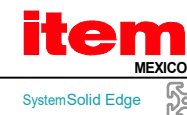

CUSTOMER: MABE	
DWG. NAME:	CS-00011205_KARAKURI STACKING_DRAFT
SOLUTION:	REV.:
Unless otherwise specified, all measures are in mm	
PAGE: 1	

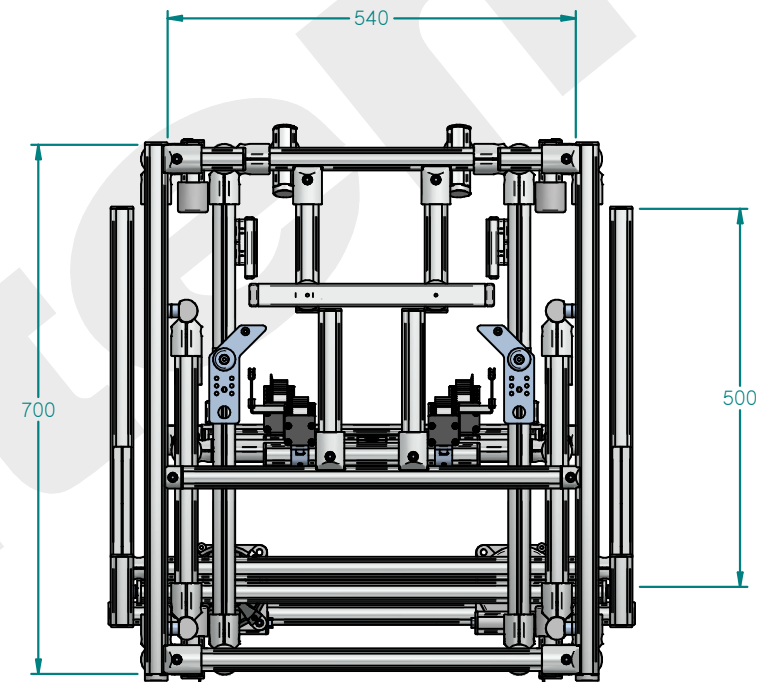
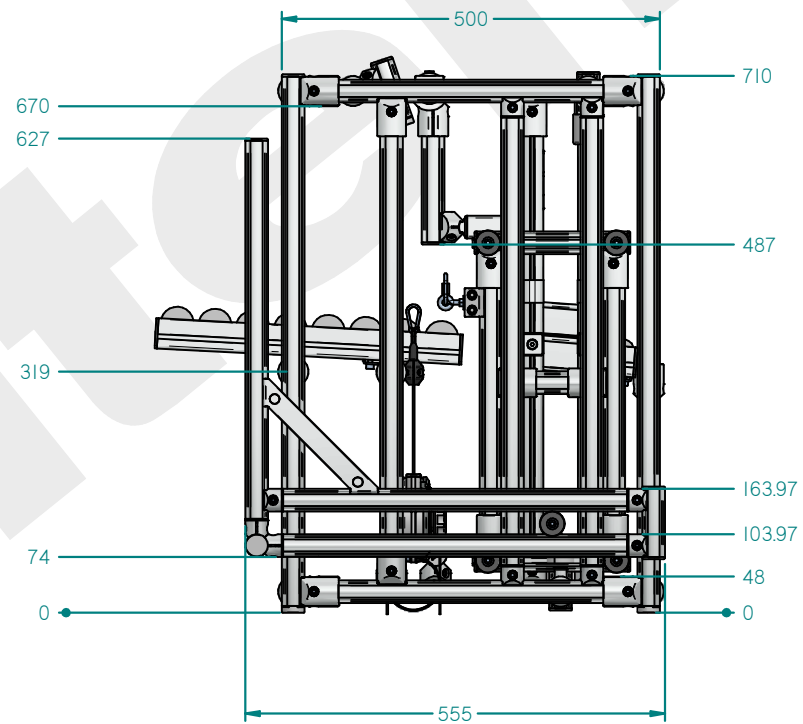
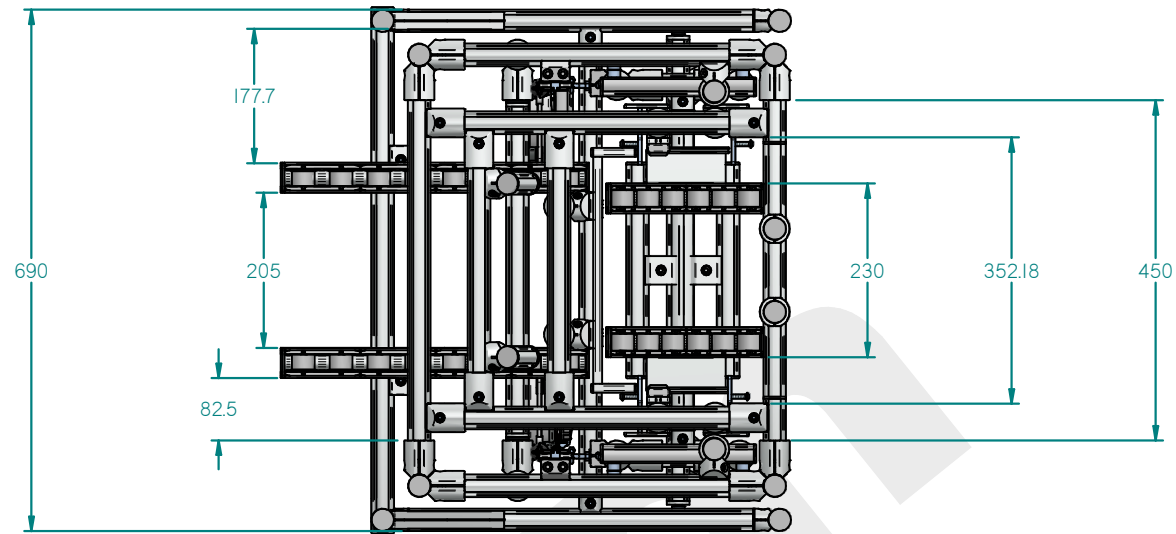

PROJECT NAME: CS-00011205_KARAKURI STACKING.asm	
DESIGN BY:	EdderAcuñaMorales/13/2023
DRAWING BY:	MSANDOVAL 6/4/2023
CUSTOMER APPROVAL	

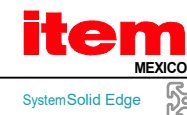

CUSTOMER: MABE	
DWG. NAME:	CS-00011205_KARAKURI STACKING_DRAFT
SOLUTION:	REV.:
Unless otherwise specified, all measures are in mm	
PAGE: 2	

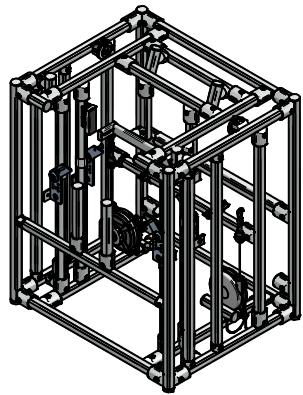

1
FRAME

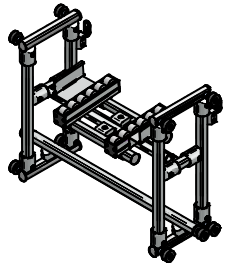

2
BOX HOLDER

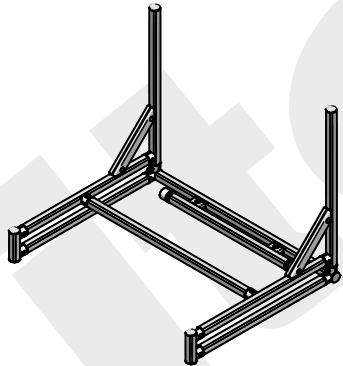

3
FRONT
STRUCTURE

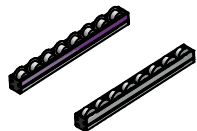

4
INPUT
CONVEYOR

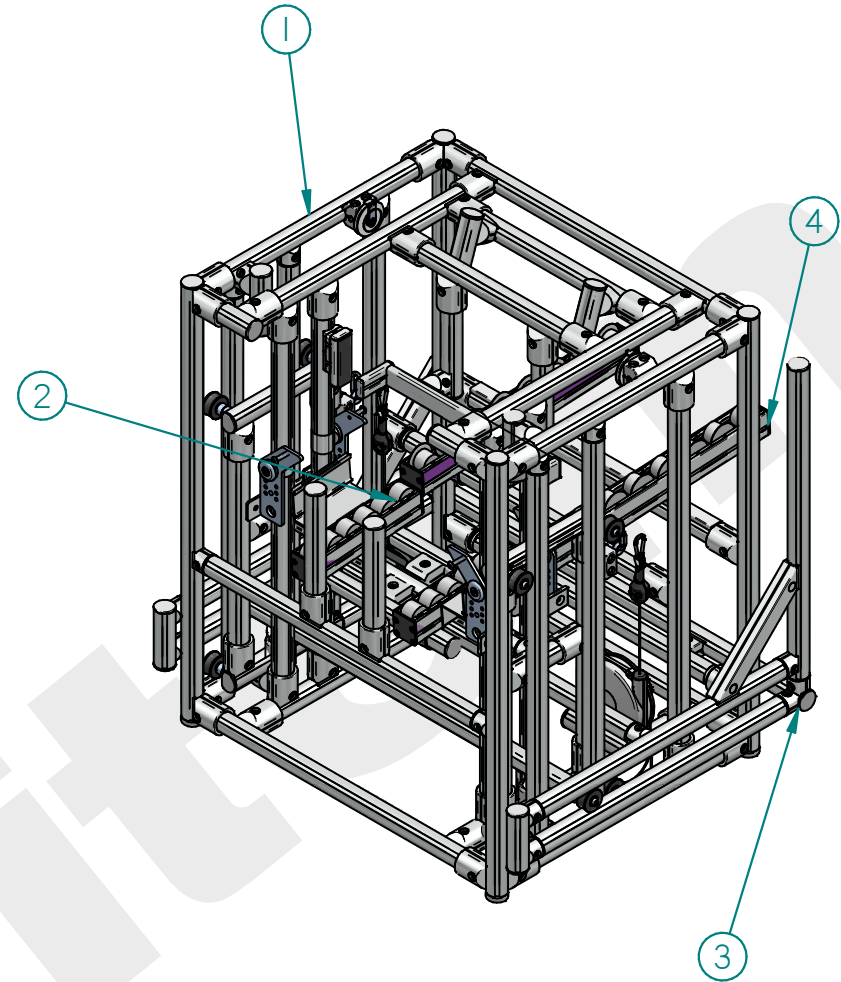

PROJECT NAME:	CS-00011205_KARAKURI STACKING.asm	
DESIGN BY:	EdderAcuñaMorales	5/13/2023
DRAWING BY:	MSANDOVAL	6/4/2023
CUSTOMER APPROVAL		



SystemSolid Edge

CUSTOMER:	MABE	
DWG. NAME:	CS-00011205_KARAKURI STACKING_DRAFT	
SOLUTION:		REV.:
Unless otherwise specified, all measures are in mm		PAGE: 3

1 FRAME

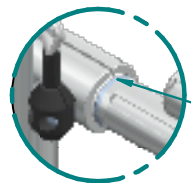
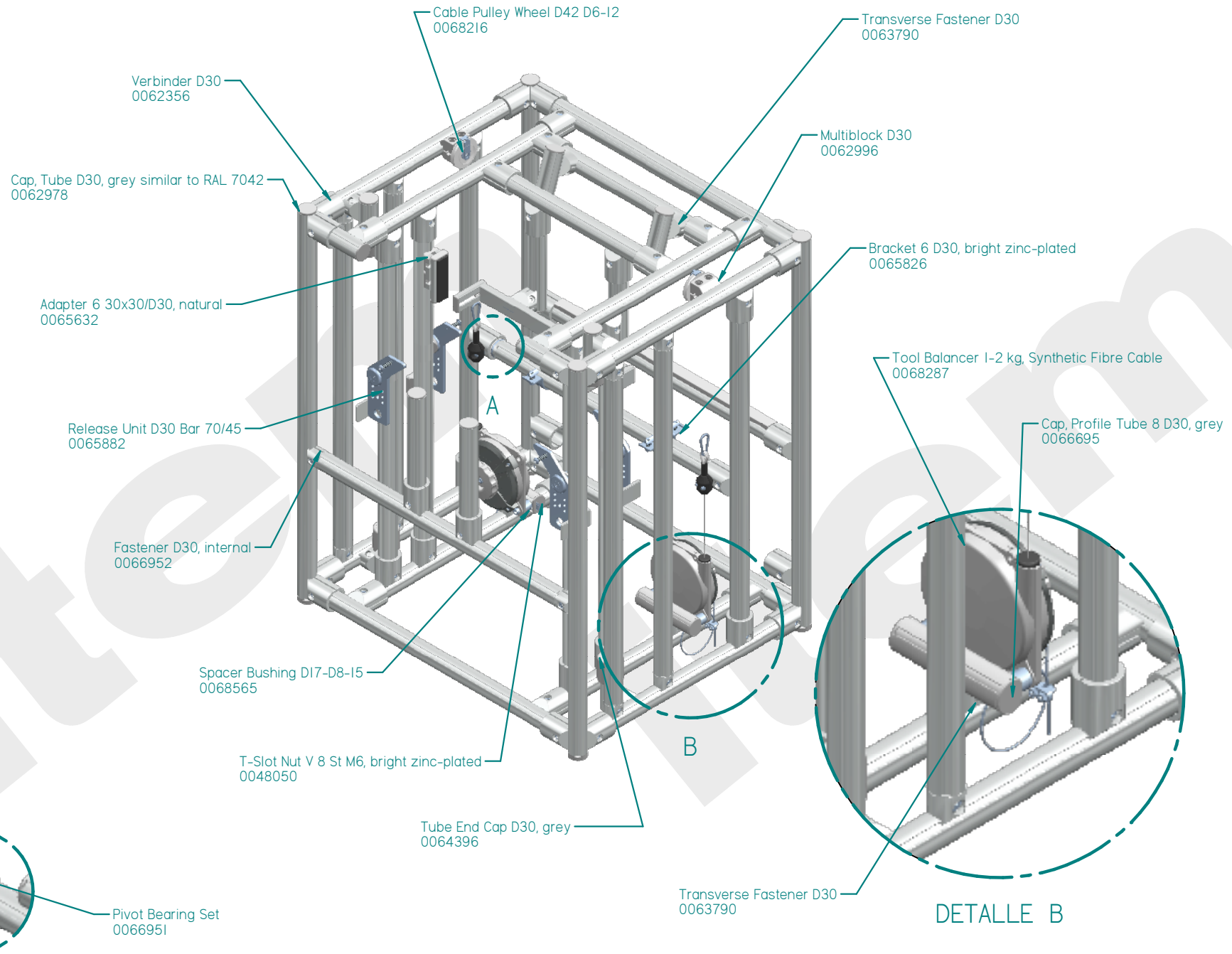

DETALLE A

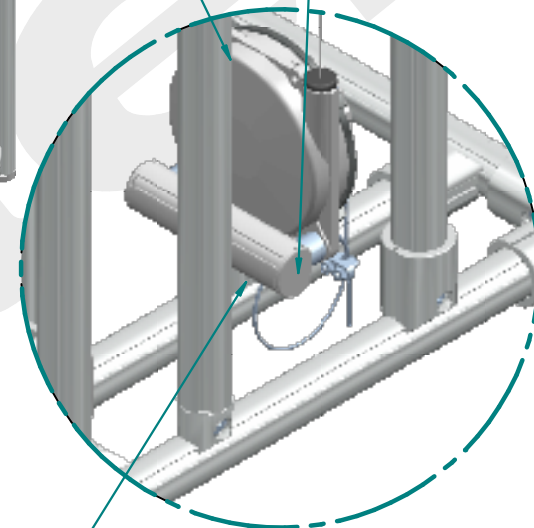

DETALLE B

PROJECT NAME:	CS-00011205_KARAKURI STACKING.asm
DESIGN BY:	EdderAcuñaMorales/13/2023
DRAWING BY:	MSANDOVAL 6/4/2023
CUSTOMER APPROVAL	

item
MEXICO

SystemSolid Edge



CUSTOMER:	MABE
DWG. NAME:	CS-00011205_KARAKURI STACKING_DRAFT
SOLUTION:	
REV.:	
Unless otherwise specified, all measures are in mm	
PAGE:	4

1 FRAME

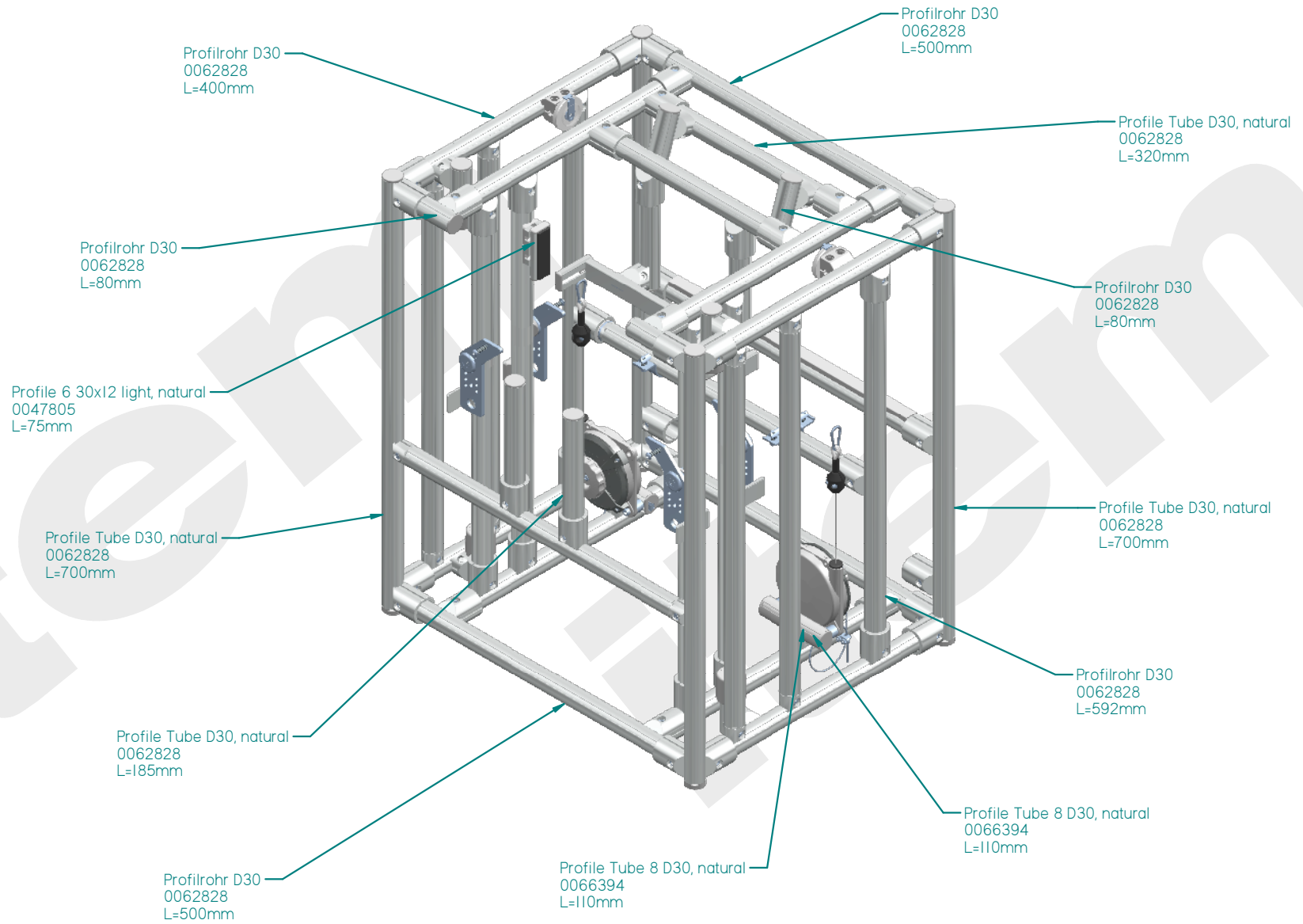

PROJECT NAME: CS-00011205_KARAKURI STACKING.asm	
DESIGN BY:	EdderAcuñaMorales/13/2023
DRAWING BY:	MSANDOVAL 6/4/2023
CUSTOMER APPROVAL	

item

MEXICO

SystemSolid Edge



CUSTOMER: MABE	
DWG. NAME:	CS-00011205_KARAKURI STACKING_DRAFT
SOLUTION:	REV.:
Unless otherwise specified, all measures are in mm	
PAGE: 5	

1 FRAME

Tension can be adjust turning this center handle.

Fix the pulley cable wheel in the variofix block

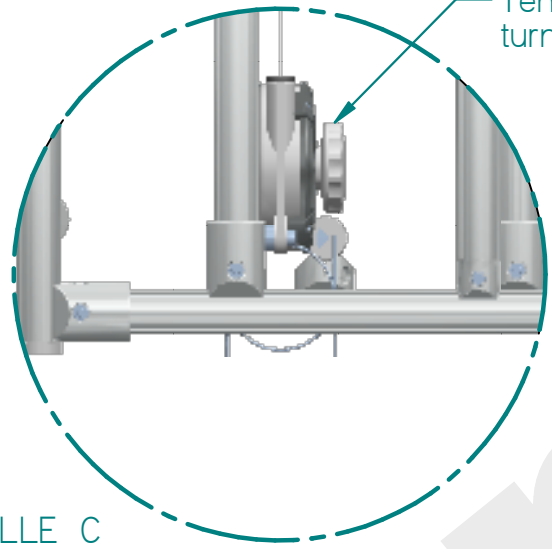

DETALLE C

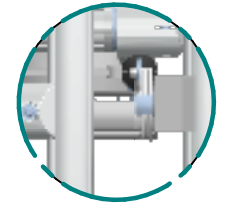
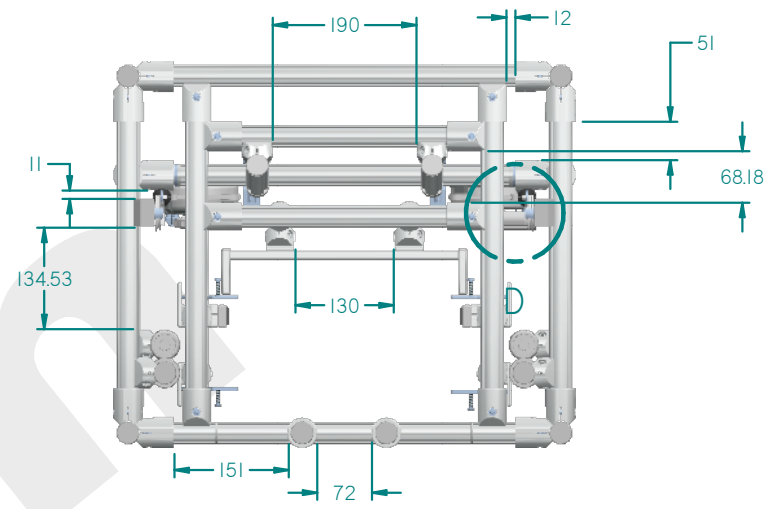

DETALLE D

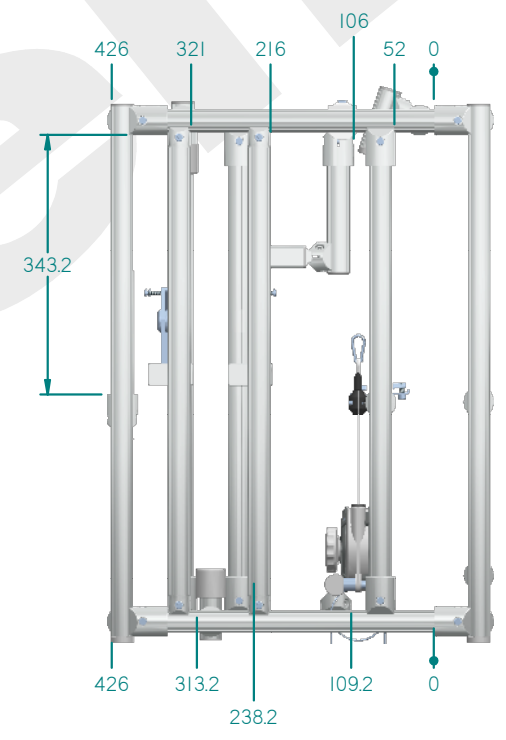
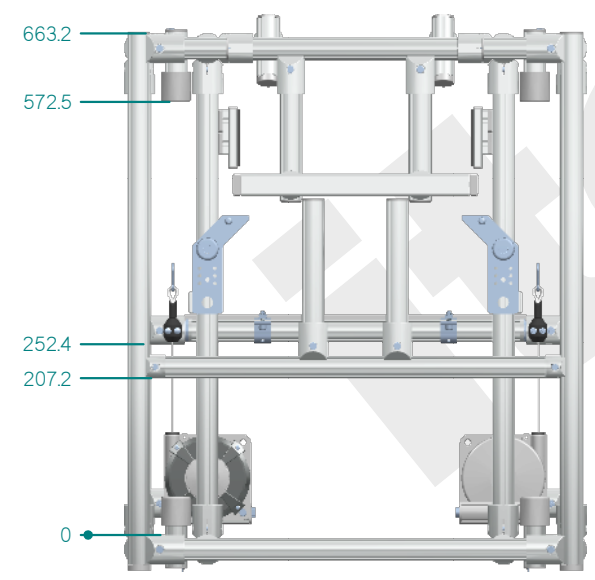
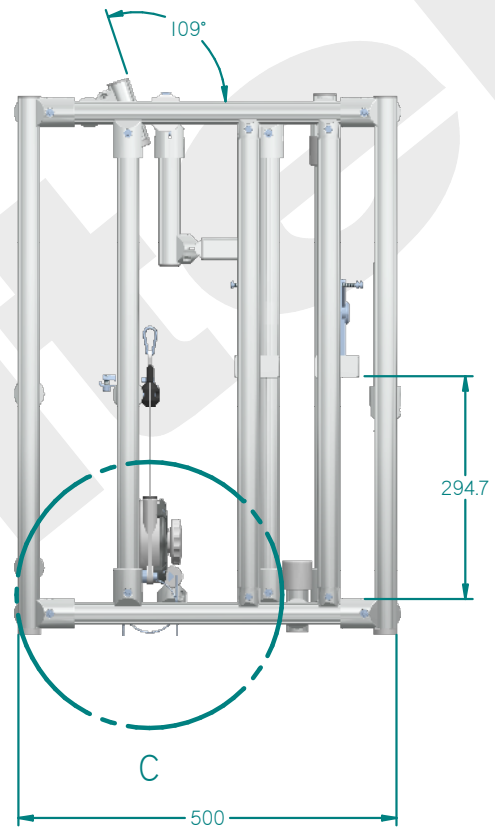

PROJECT NAME:	CS-00011205_KARAKURI STACKING.asm
DESIGN BY:	EdderAcuñaMorales/13/2023
DRAWING BY:	MSANDOVAL 6/4/2023
CUSTOMER APPROVAL	



CUSTOMER:	MABE
DWG. NAME:	CS-00011205_KARAKURI STACKING_DRAFT
SOLUTION:	
REV.:	
Unless otherwise specified, all measures are in mm	
PAGE:	6

2 BOX HOLDER

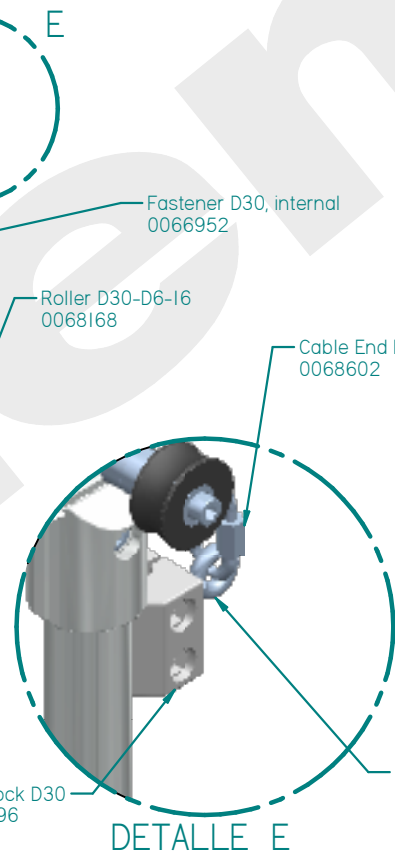
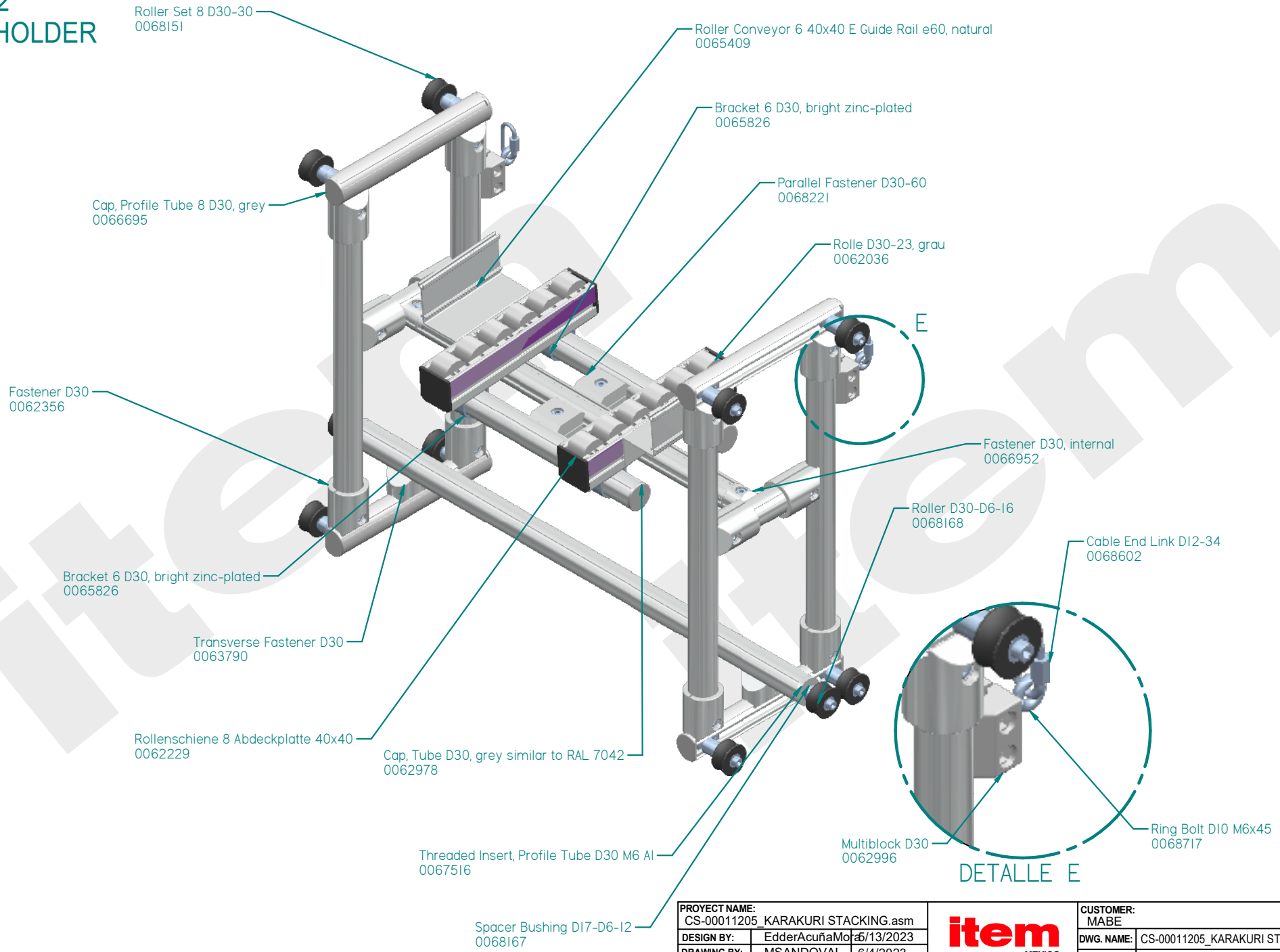

DETALLE E

PROJECT NAME: CS-00011205_KARAKURI STACKING.asm			CUSTOMER: MABE	
DESIGN BY: EdderAcuñaMorales/13/2023	DRAWING BY: MSANDOVAL 6/4/2023		DWG. NAME: CS-00011205_KARAKURI STACKING_DRAFT	REV.:
CUSTOMER APPROVAL		SystemSolid Edge 	Unless otherwise specified, all measures are in mm	PAGE: 7

2 BOX HOLDER

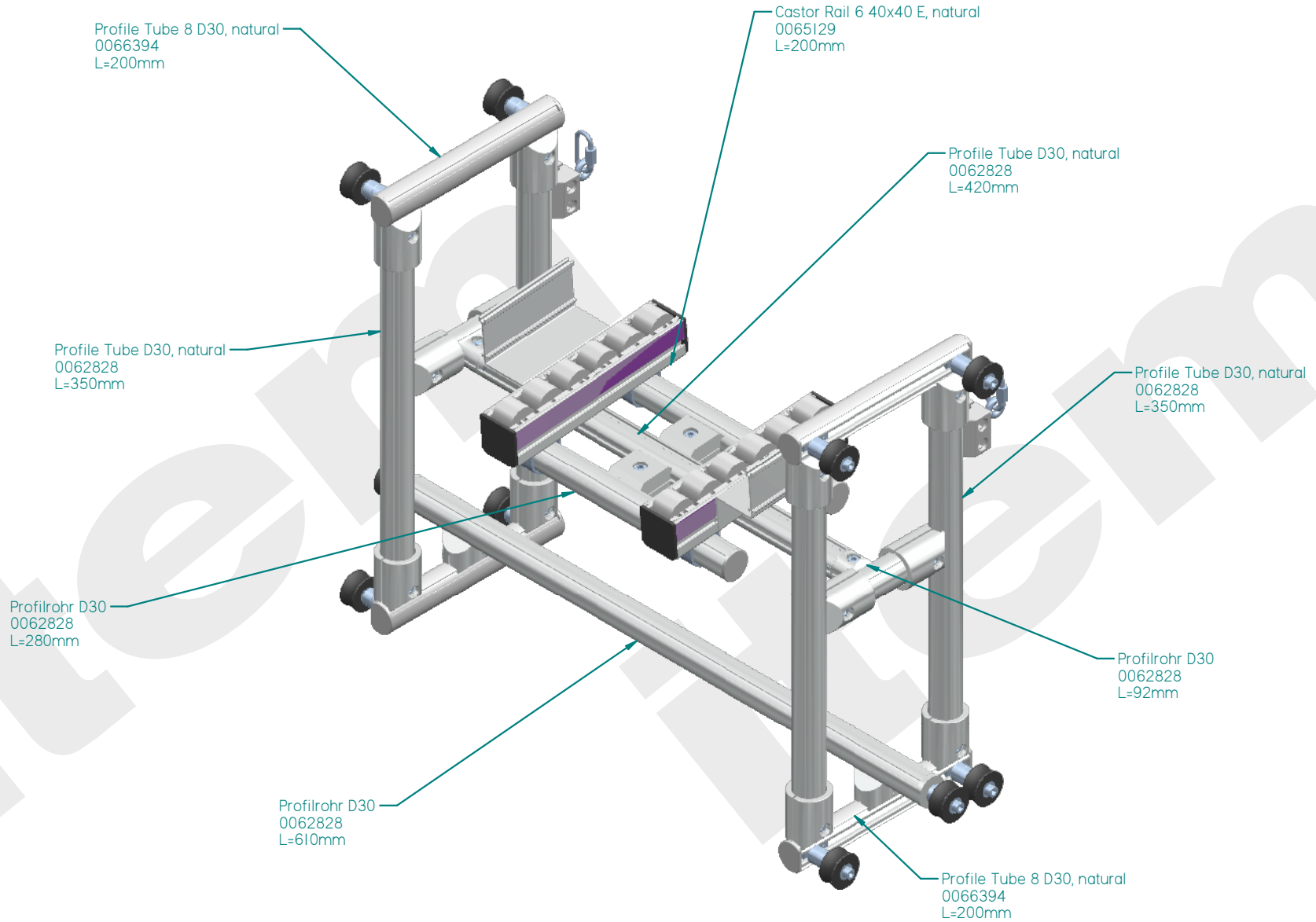

PROYECT NAME: CS-00011205_KARAKURI STACKING.asm	
DESIGN BY:	EdderAcuñaMorales/13/2023
DRAWING BY:	MSANDOVAL 6/4/2023
CUSTOMER APPROVAL	



CUSTOMER: MABE	
DWG. NAME:	CS-00011205_KARAKURI STACKING_DRAFT
SOLUTION:	REV.:
Unless otherwise specified, all measures are in mm	
PAGE: 8	

2 BOX HOLDER

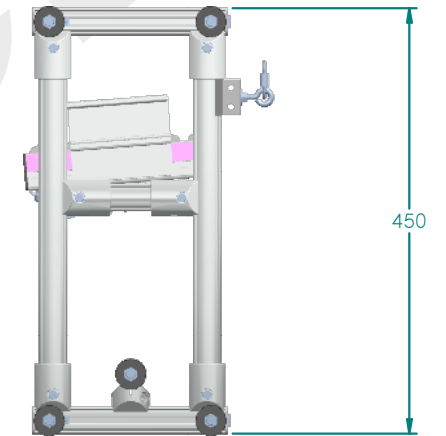
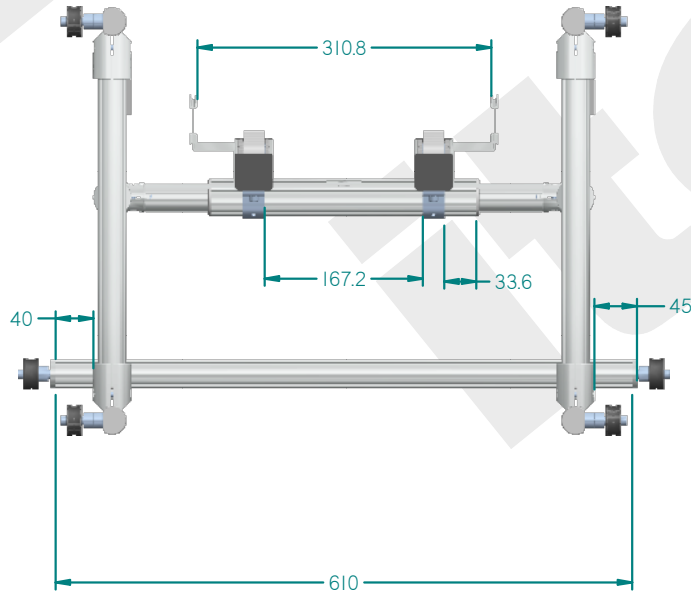
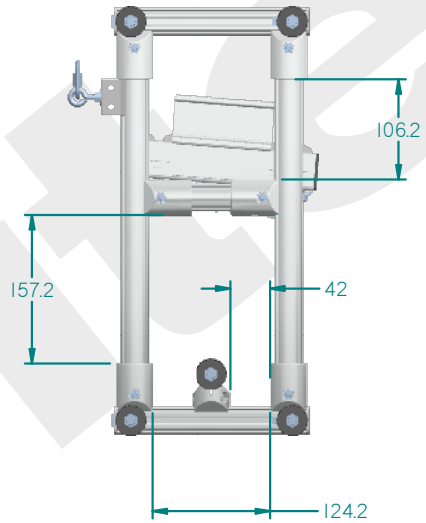
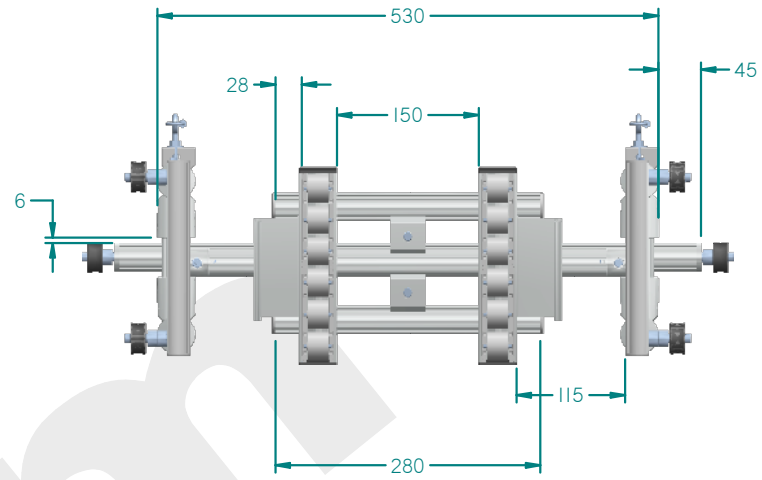

PROJECT NAME: CS-00011205_KARAKURI STACKING.asm	
DESIGN BY:	EdderAcuñaMorales/13/2023
DRAWING BY:	MSANDOVAL 6/4/2023
CUSTOMER APPROVAL	



CUSTOMER: MABE	
DWG. NAME:	CS-00011205_KARAKURI STACKING_DRAFT
SOLUTION:	REV.:
Unless otherwise specified, all measures are in mm	
PAGE: 9	

3 FRONT STRUCTURE

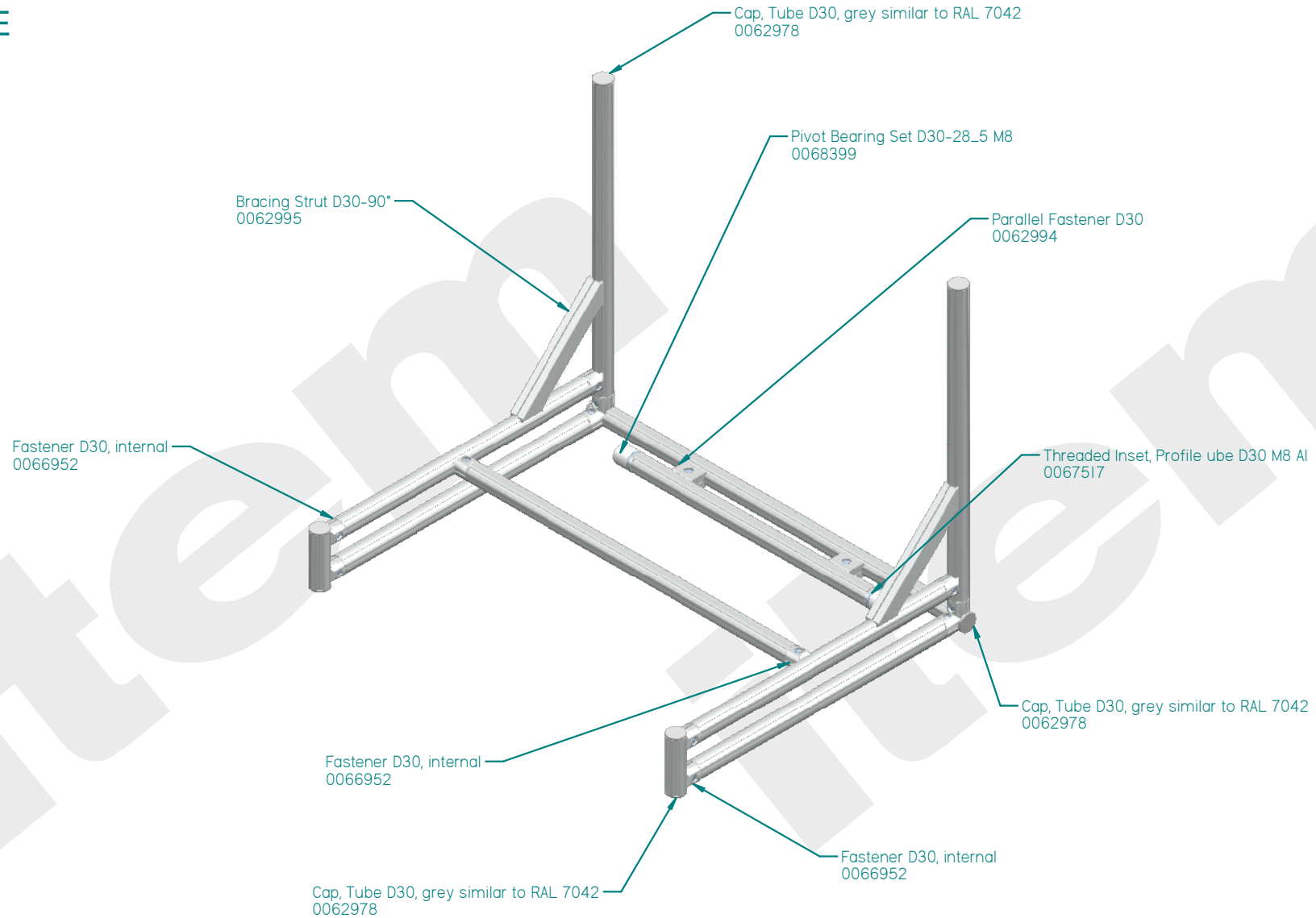

PROYECT NAME: CS-00011205_KARAKURI STACKING.asm	
DESIGN BY:	EdderAcuñaMojas/13/2023
DRAWING BY:	MSANDOVAL 6/4/2023
CUSTOMER APPROVAL	

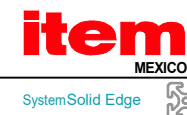

CUSTOMER: MABE	
DWG. NAME:	CS-00011205_KARAKURI STACKING_DRAFT
SOLUTION:	REV.:
Unless otherwise specified, all measures are in mm	
PAGE: 10	

3 FRONT STRUCTURE

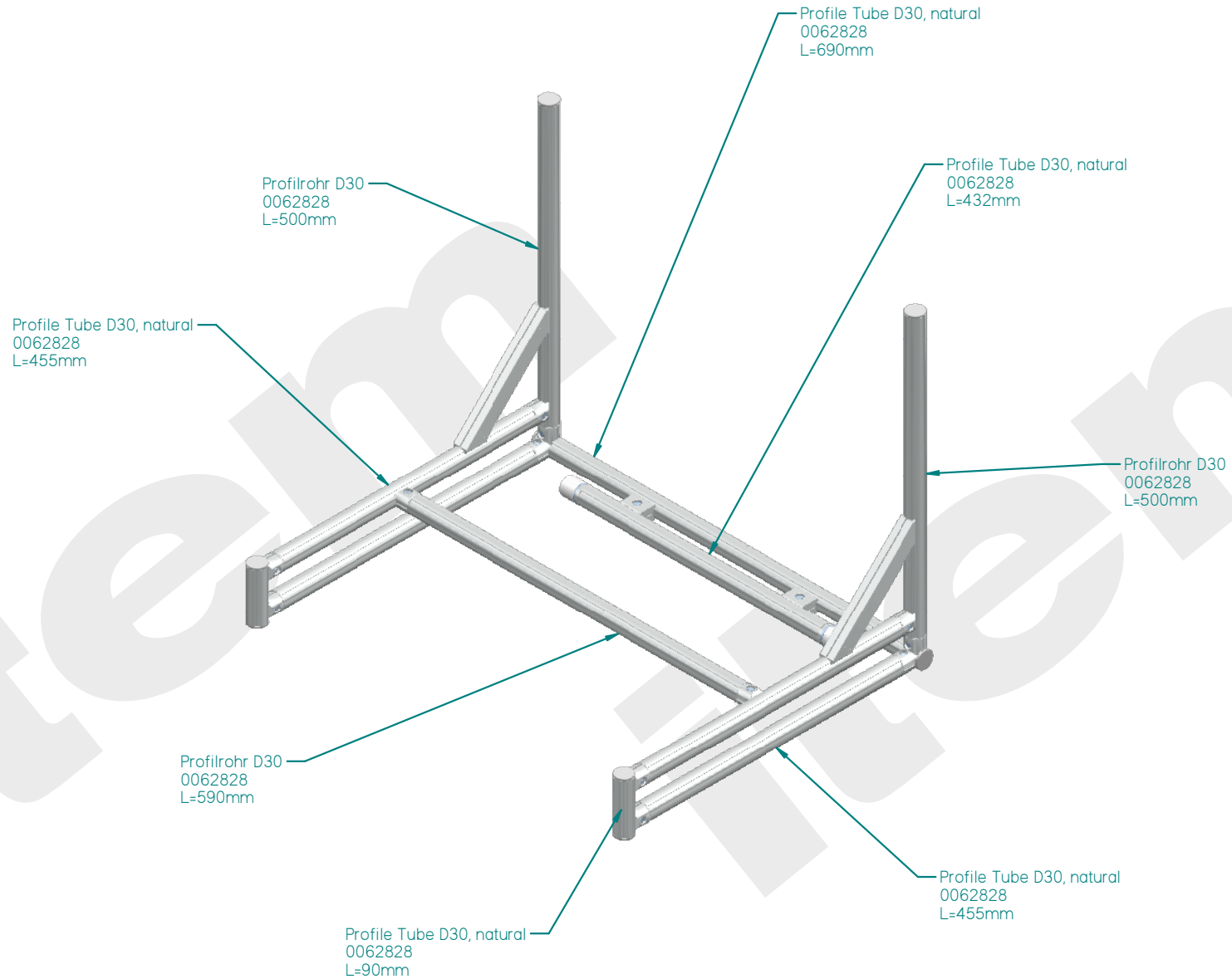

PROYECT NAME: CS-00011205_KARAKURI STACKING.asm	
DESIGN BY:	EdderAcuñaMorales/13/2023
DRAWING BY:	MSANDOVAL 6/4/2023
CUSTOMER APPROVAL	



SystemSolid Edge 

CUSTOMER: MABE	
DWG. NAME:	CS-00011205_KARAKURI STACKING_DRAFT
SOLUTION:	REV.:
Unless otherwise specified, all measures are in mm	
PAGE: 11	

3 FRONT STRUCTURE

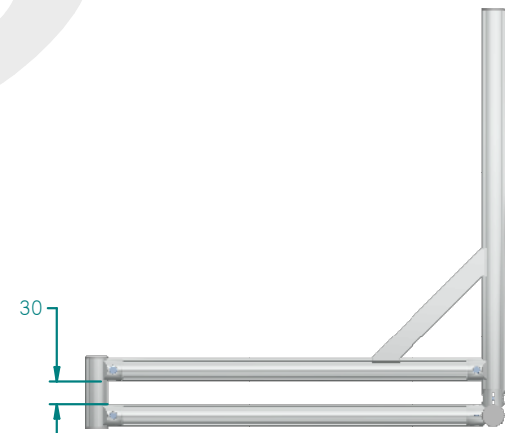
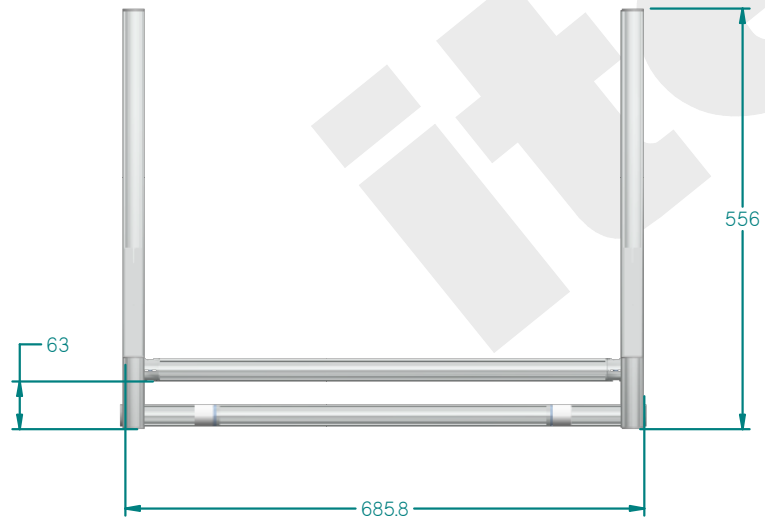
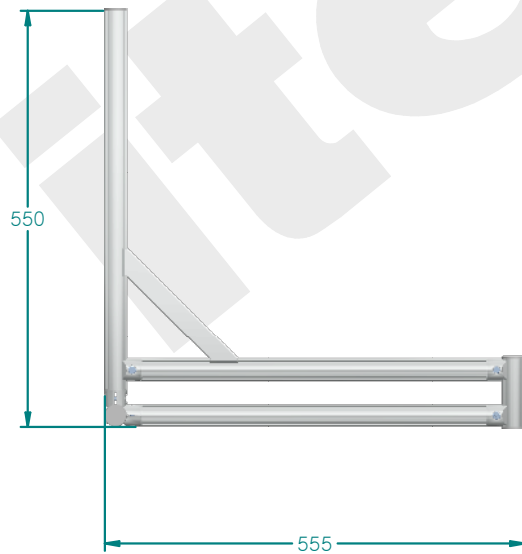
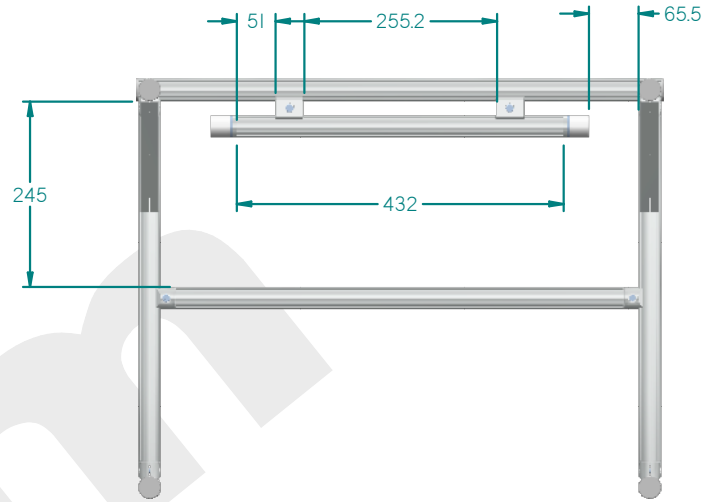

PROJECT NAME: CS-00011205_KARAKURI STACKING.asm	
DESIGN BY:	EdderAcuñaMorales/13/2023
DRAWING BY:	MSANDOVAL 6/4/2023
CUSTOMER APPROVAL	

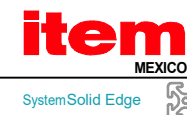

CUSTOMER: MABE	
DWG. NAME:	CS-00011205_KARAKURI STACKING_DRAFT
SOLUTION:	REV.:
Unless otherwise specified, all measures are in mm	
PAGE: 12	

4 INPUT CONVEYOR

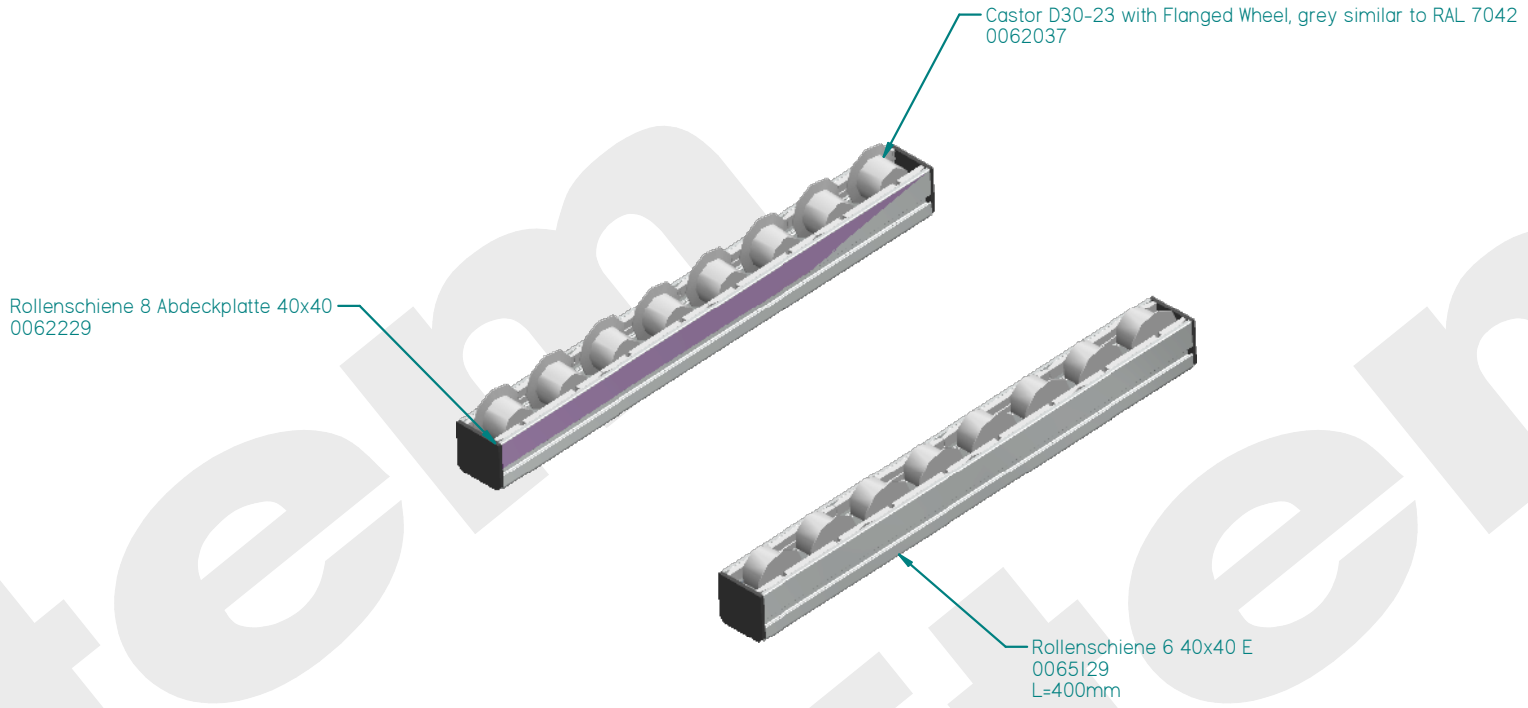

PROYECT NAME: CS-00011205_KARAKURI STACKING.asm			CUSTOMER: MABE	
DESIGN BY: EdderAcuñaMojas	5/13/2023		DWG. NAME: CS-00011205_KARAKURI STACKING_DRAFT	REV.:
DRAWING BY: MSANDOVAL	6/4/2023	SOLUTION:	REV.:	
CUSTOMER APPROVAL		SystemSolid Edge 	Unless otherwise specified, all measures are in mm	PAGE: 13

ASSEMBLY

T-slots must be inside of the profile.

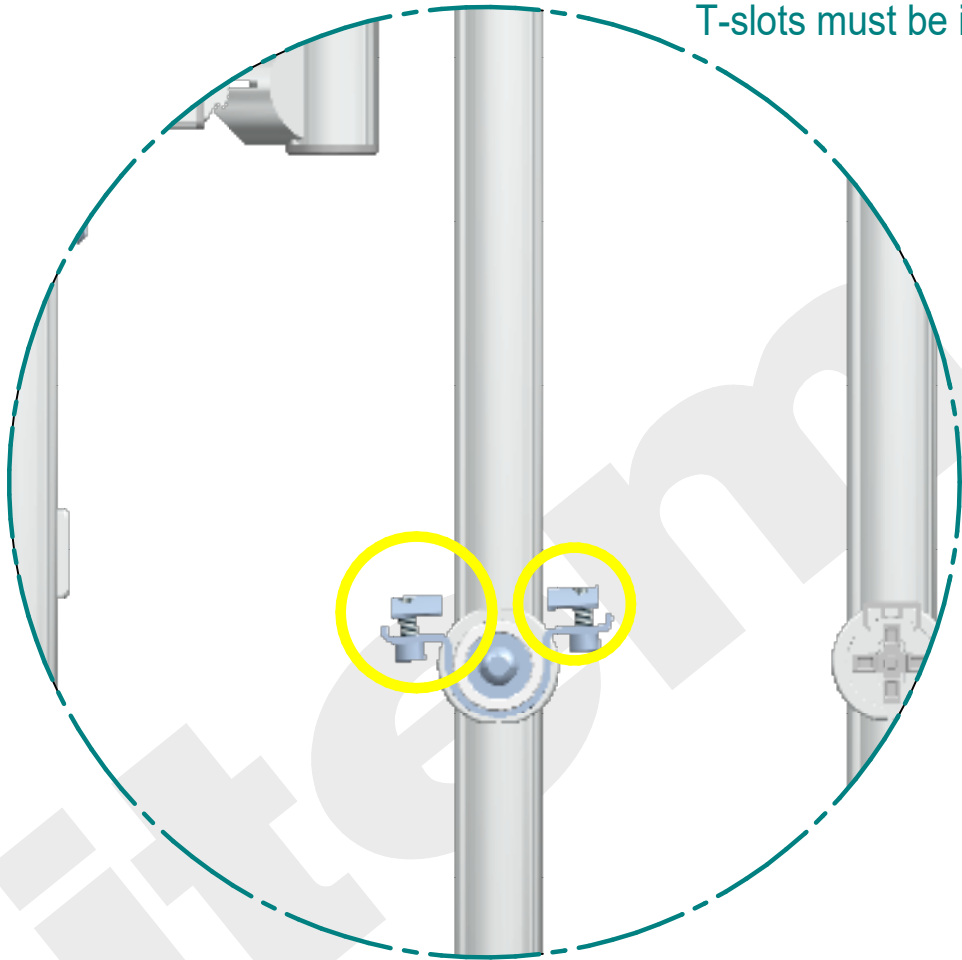

DETALLE J

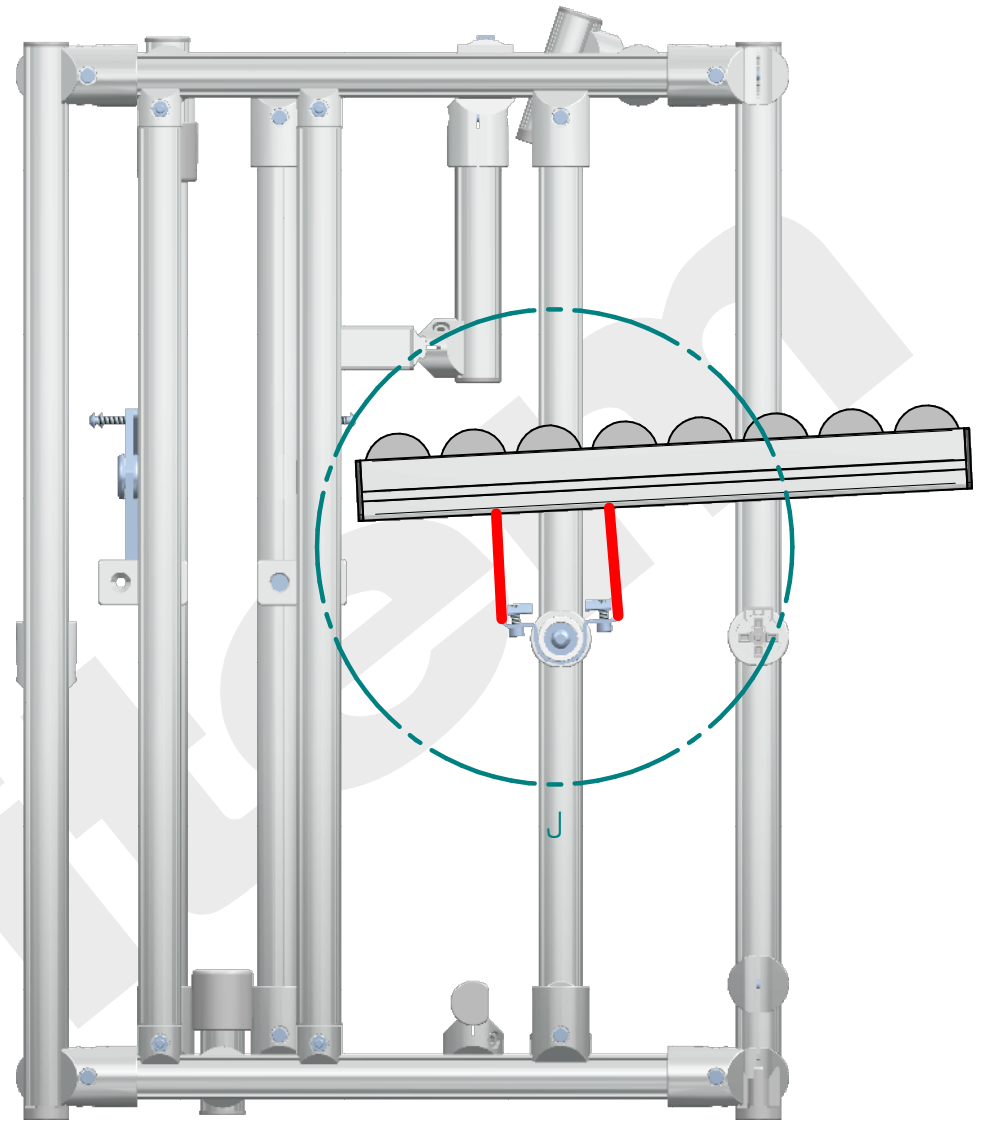

PROJECT NAME:	CS-00011205_KARAKURI STACKING.asm
DESIGN BY:	EdderAcuñaMorales/13/2023
DRAWING BY:	MSANDOVAL 6/4/2023
CUSTOMER APPROVAL	

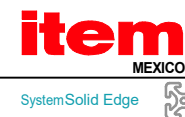

CUSTOMER:	MABE
DWG. NAME:	CS-00011205_KARAKURI STACKING_DRAFT
SOLUTION:	
REV.:	
Unless otherwise specified, all measures are in mm	
PAGE:	14

ASSEMBLY

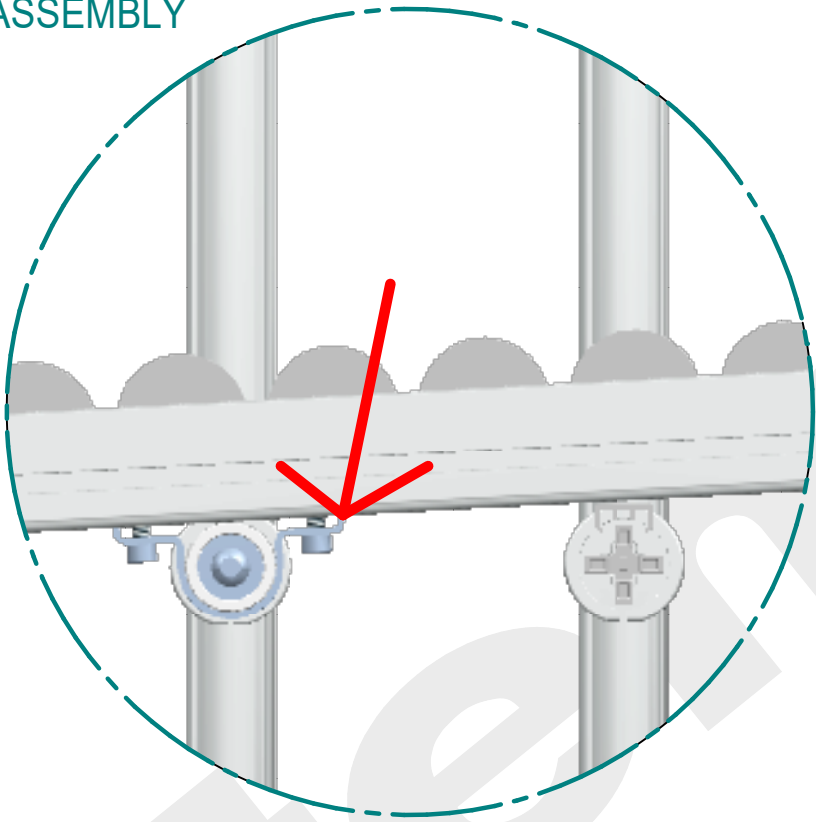

DETALLE F

To fix the conveyors to the frame, we are going to use the Bracket 65826 of the frame, keeping a distance of 50.5 mm and an inclination of 3°.

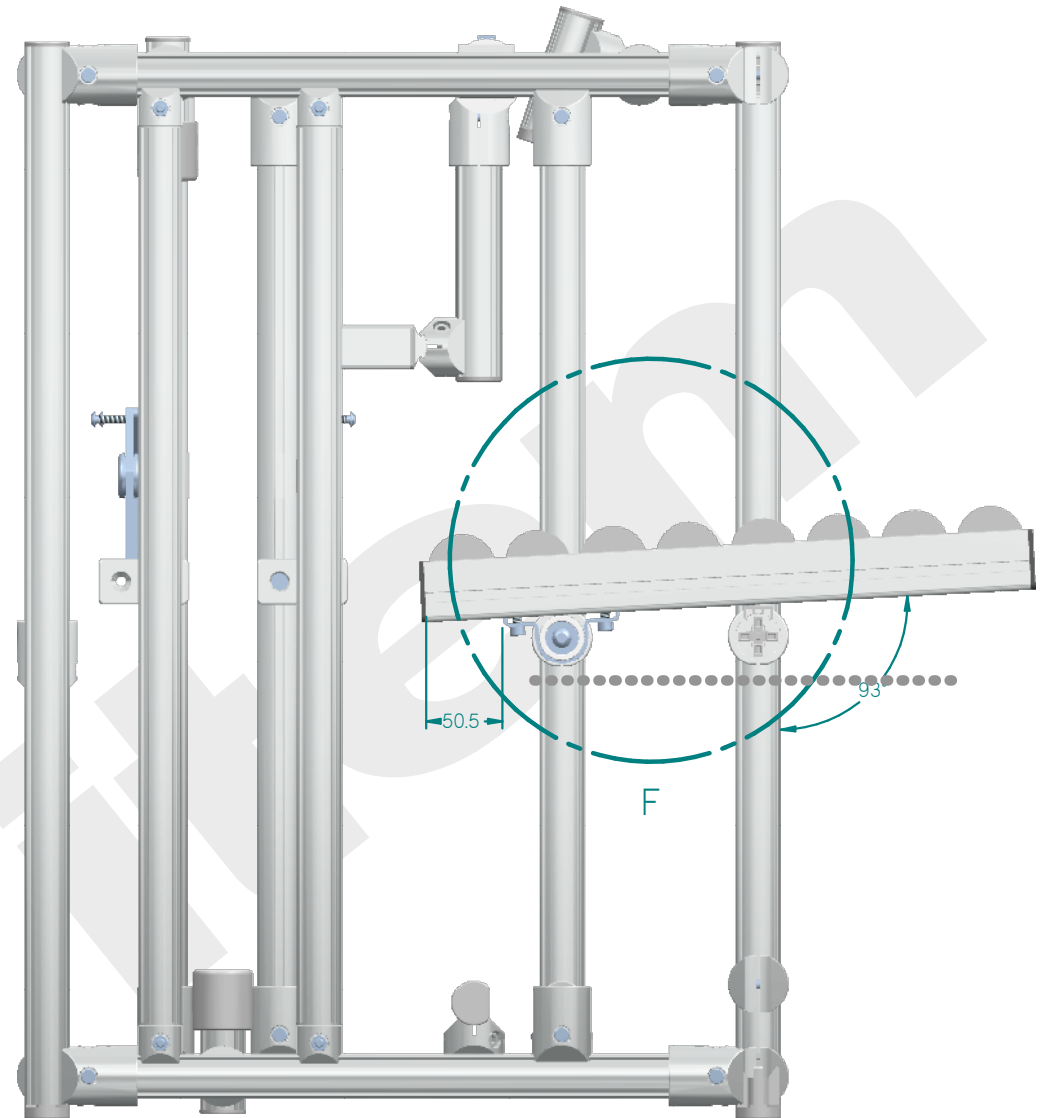

PROJECT NAME:	CS-00011205_KARAKURI STACKING.asm
DESIGN BY:	EdderAcuñaMorales/13/2023
DRAWING BY:	MSANDOVAL 6/4/2023
CUSTOMER APPROVAL	

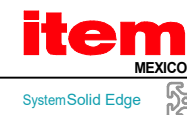

CUSTOMER:	MABE
DWG. NAME:	CS-00011205_KARAKURI STACKING_DRAFT
SOLUTION:	
REV.:	
Unless otherwise specified, all measures are in mm	
PAGE:	15

ASSEMBLY



DETALLE G

Connect the tool balancer cable to the box holder, but this cable should be through the pulley, remember tension can be adjust on the tool balancer.
When we put together these sub-assemblies we should keep in mind, that the 4 rollers should be align to the D30 profiles in both sides.

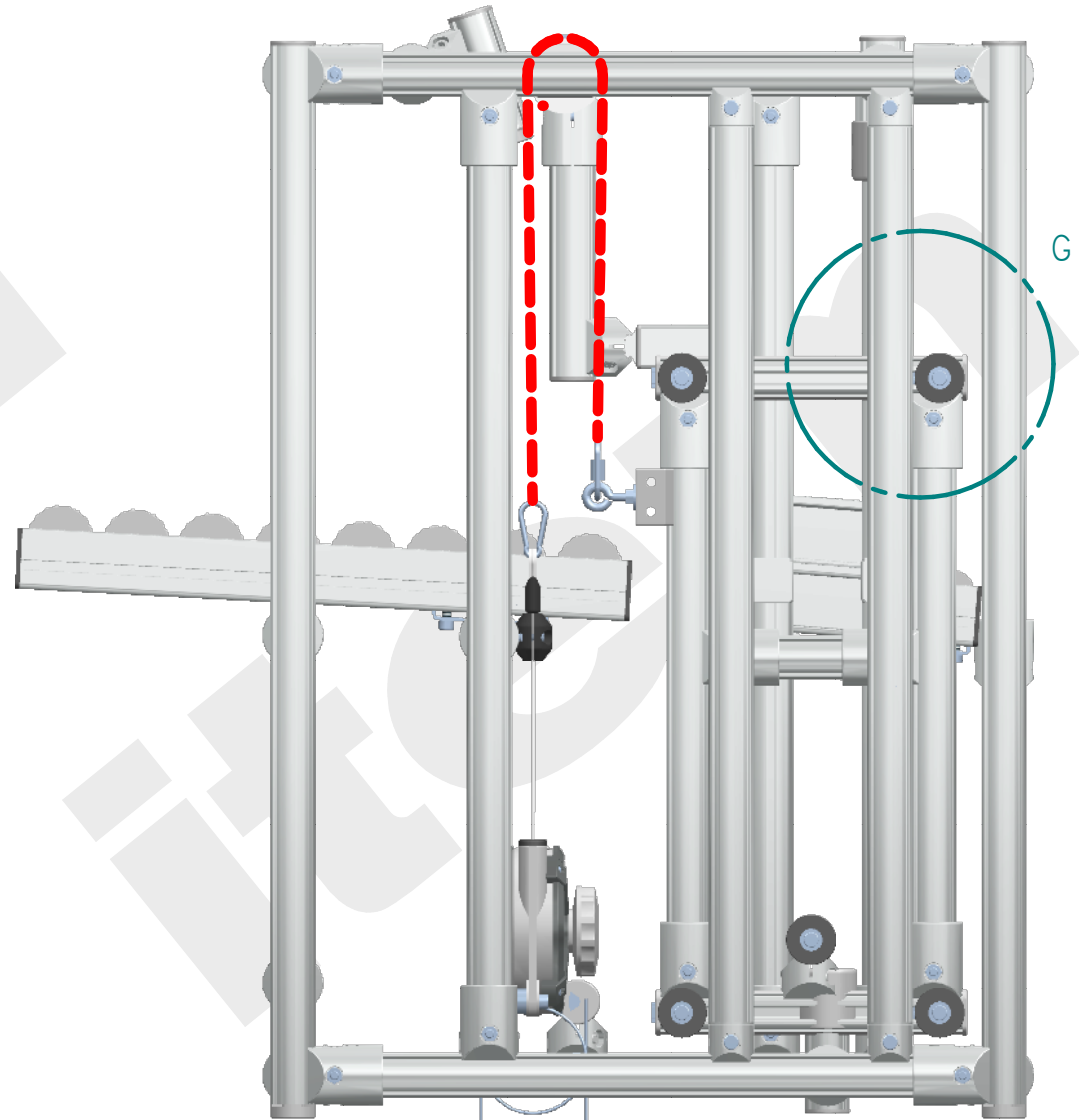

PROYECT NAME:	CS-00011205_KARAKURI STACKING.asm	
DESIGN BY:	EdderAcuñaMojca	5/13/2023
DRAWING BY:	MSANDOVAL	6/4/2023
CUSTOMER APPROVAL		

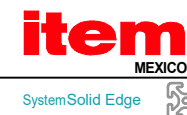

CUSTOMER:	MABE	
DWG. NAME:	CS-00011205_KARAKURI STACKING_DRAFT	
SOLUTION:		REV.:
Unless otherwise specified, all measures are in mm		
		PAGE: 16

ASSEMBLY

For mounting the box holder is necessary, remove the top rollers and after assembly the two structures, the profiles should be aseemble again.

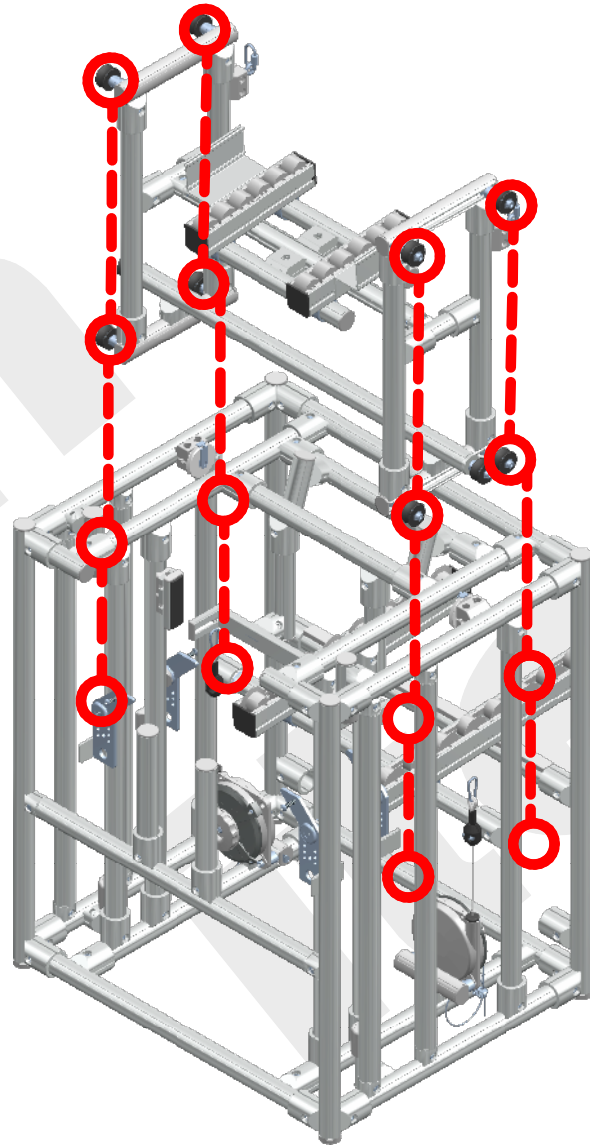

PROYECT NAME: CS-00011205_KARAKURI STACKING.asm	
DESIGN BY:	EdderAcuñaMojas/13/2023
DRAWING BY:	MSANDOVAL 6/4/2023
CUSTOMER APPROVAL	

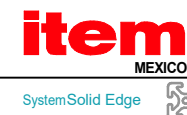

CUSTOMER: MABE	
DWG. NAME:	CS-00011205_KARAKURI STACKING_DRAFT
SOLUTION:	REV.:
Unless otherwise specified, all measures are in mm	
PAGE: 17	

ASSEMBLY

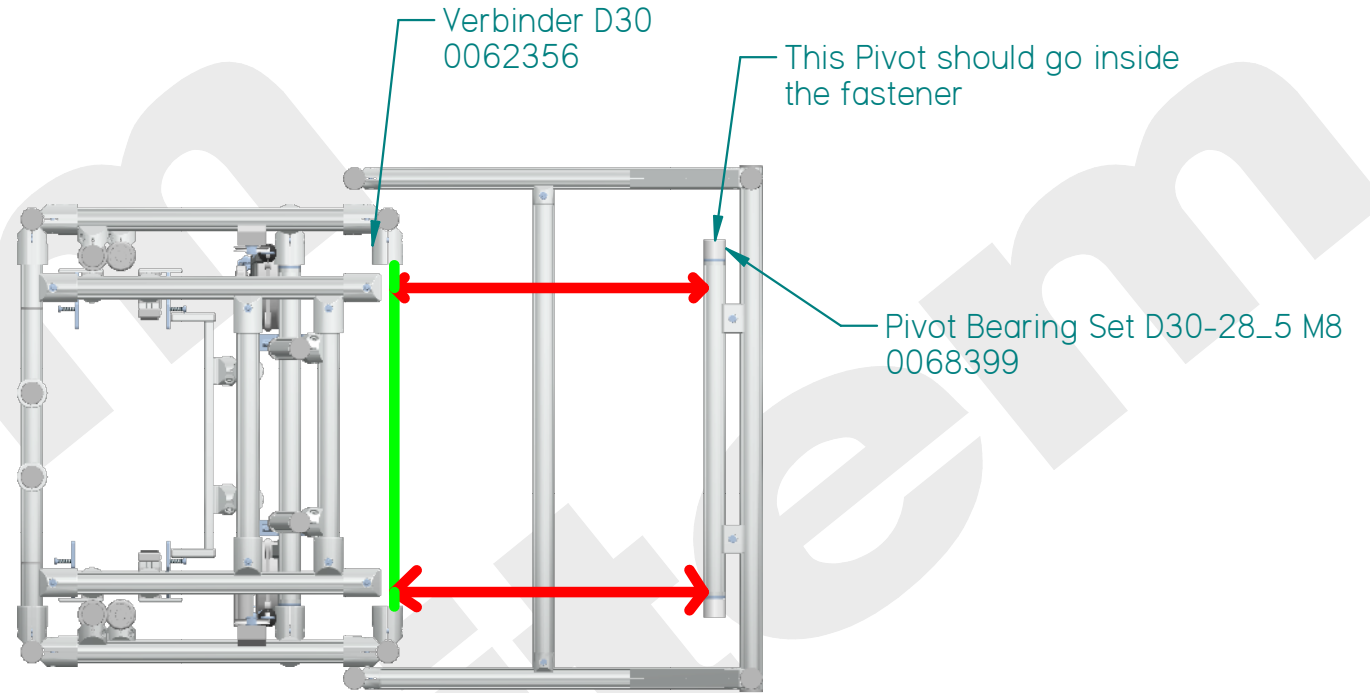

PROYECT NAME:	CS-00011205_KARAKURI STACKING.asm	
DESIGN BY:	EdderAcuñaMoj	5/13/2023
DRAWING BY:	MSANDOVAL	6/4/2023
CUSTOMER APPROVAL		

item
MEXICO

SystemSolid Edge

CUSTOMER:	MABE	
DWG. NAME:	CS-00011205_KARAKURI STACKING_DRAFT	
SOLUTION:		REV.:
Unless otherwise specified, all measures are in mm		
		PAGE: 18

ASSEMBLY

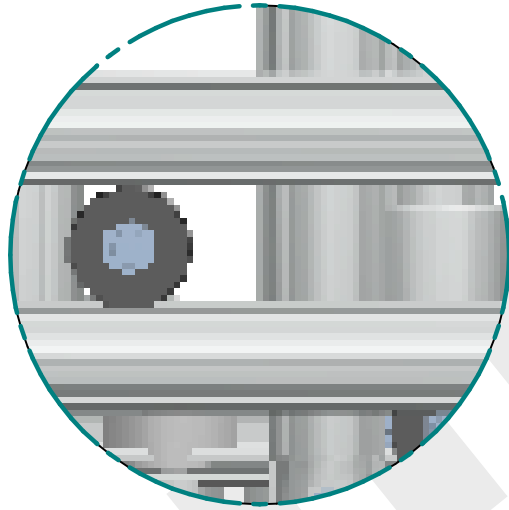

DETALLE 1

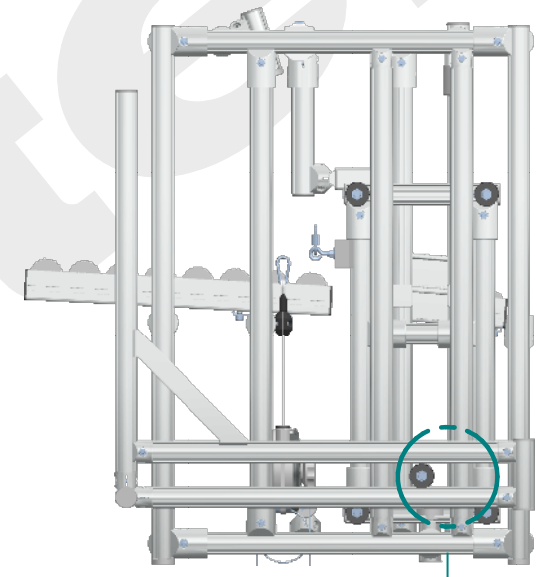
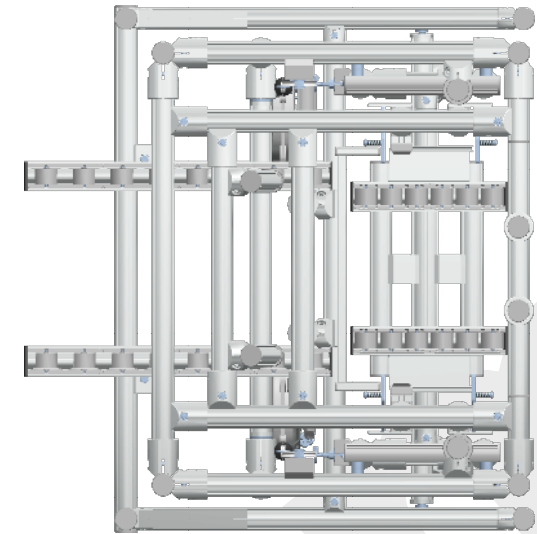

To join the Front Structure to the assembly, we are going to use the pivot bearings at the front of the assembly, to join the Frame to it, we should guarantee that the roller of the Box Holder is between the two side D30 Tubes.

PROJECT NAME: CS-00011205_KARAKURI STACKING.asm			CUSTOMER: MABE	
DESIGN BY: EdderAcuñaMojas	5/13/2023		DWG. NAME: CS-00011205_KARAKURI STACKING_DRAFT	REV.:
DRAWING BY: MSANDOVAL	6/4/2023	SOLUTION:	Unless otherwise specified, all measures are in mm	PAGE: 19
CUSTOMER APPROVAL		SystemSolid Edge		

Great job!
You finished the assembly, at this moment you only need to check the flow of your box or package and adjust if it's necessary.
Thanks a lot!

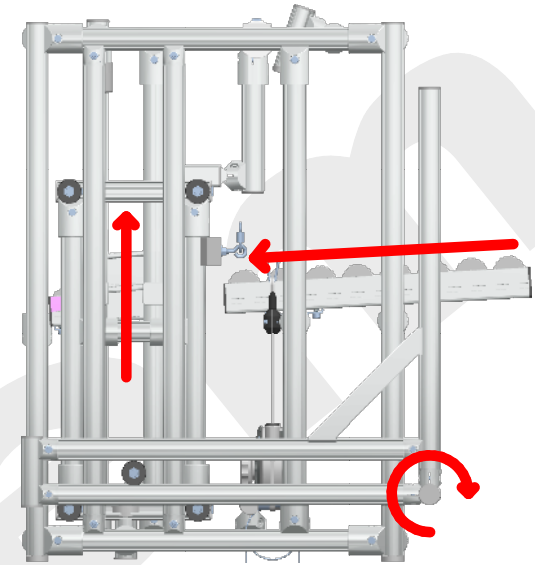

PROYECT NAME: CS-00011205_KARAKURI STACKING.asm		item MEXICO	CUSTOMER: MABE	
DESIGN BY:	EdderAcuñaMojas/13/2023		DWG. NAME:	CS-00011205_KARAKURI STACKING_DRAFT
DRAWING BY:	MSANDOVAL 6/4/2023	SOLUTION:	REV.:	
CUSTOMER APPROVAL		SystemSolid Edge 	Unless otherwise specified, all measures are in mm	PAGE: 20