

PROJECT NAME:	CS-00011206_KARAKURI USTAKING.asm	
DESIGN BY:	EdderAcuñaMoj	5/14/2023
DRAWING BY:	MSANDOVAL	6/5/2023
CUSTOMER APPROVAL		

item
MEXICO

SystemSolid Edge 

CUSTOMER:	MABE	
DWG. NAME:	CS-00011206_KARAKURI USTAKING_Draft	
SOLUTION:		REV.:
Unless otherwise specified, all measures are in mm		
		PAGE: 1

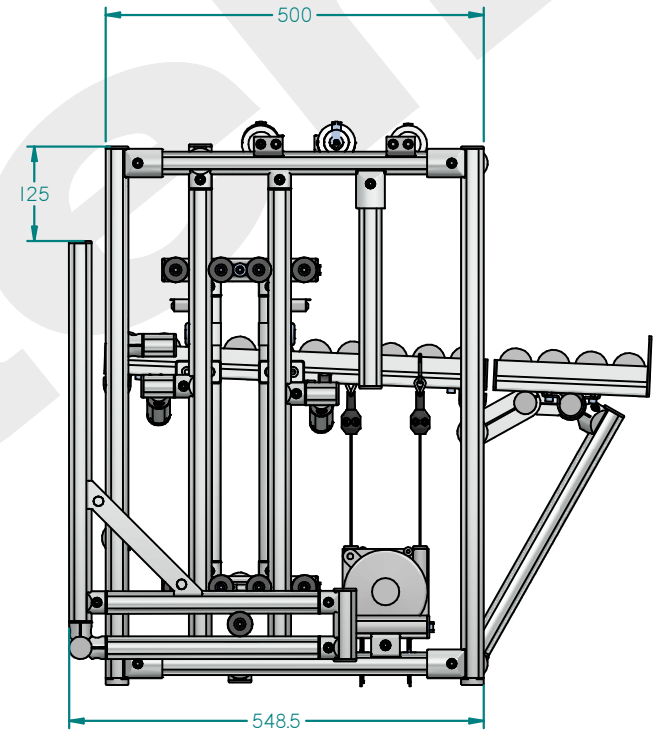
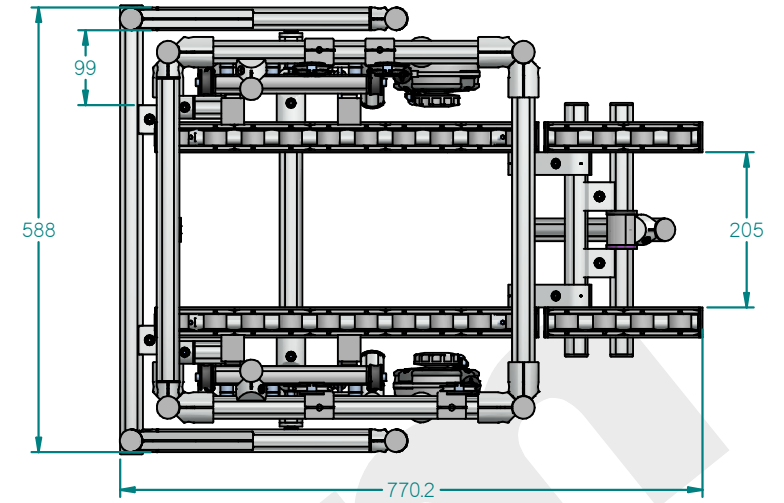
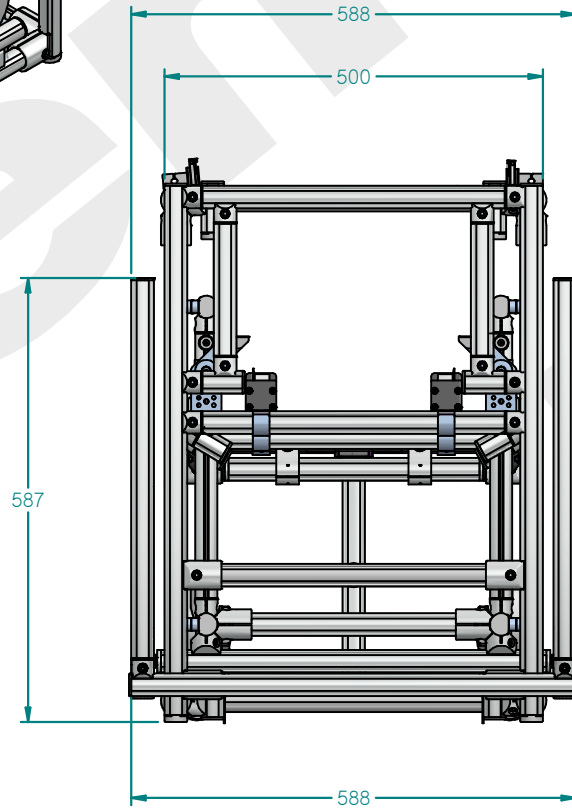
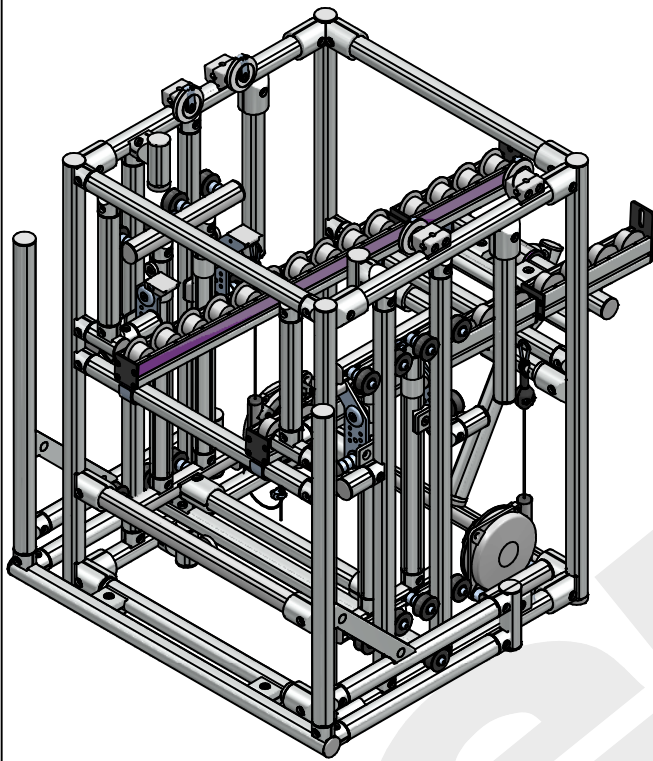

PROJECT NAME:	CS-00011206_KARAKURI USTAKING.asm
DESIGN BY:	EdderAcuñaMorales/14/2023
DRAWING BY:	MSANDOVAL 6/5/2023
CUSTOMER APPROVAL	

item
MEXICO

SystemSolid Edge 

CUSTOMER:	MABE
DWG. NAME:	CS-00011206_KARAKURI USTAKING_Draft
SOLUTION:	
REV.:	
Unless otherwise specified, all measures are in mm	
PAGE:	2

1
FRAME

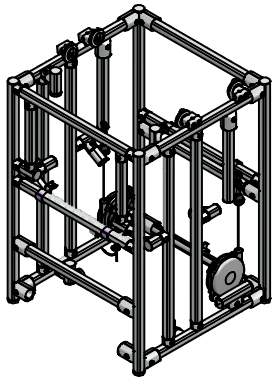

2
BASKET

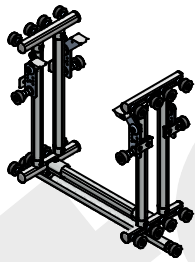

3
FRONT
STRUCTURE

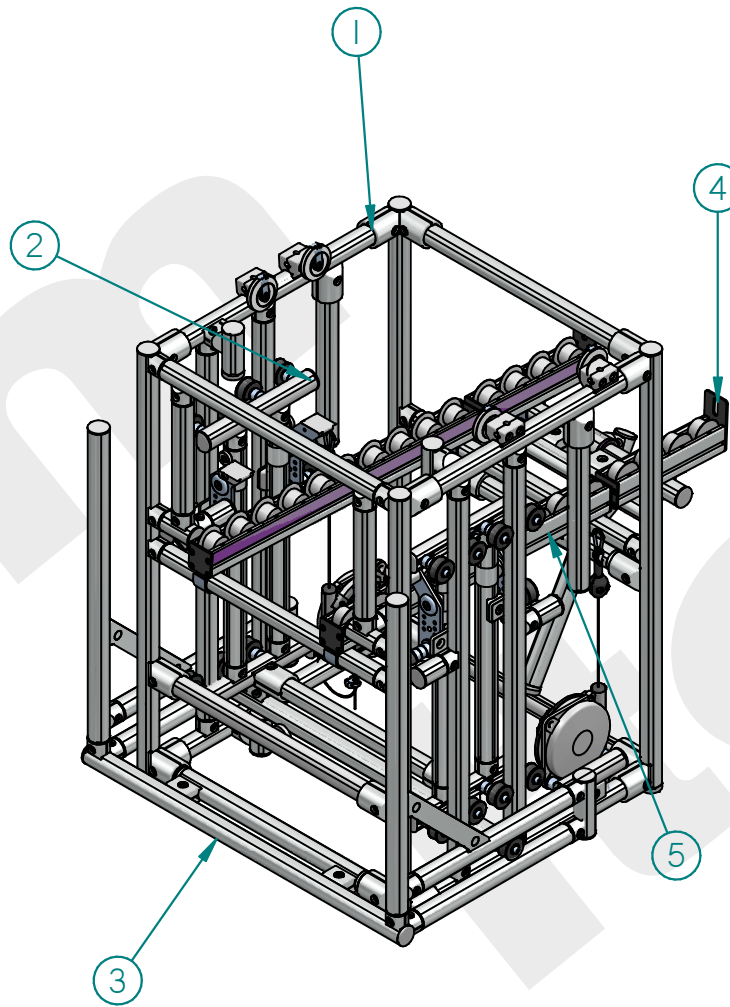
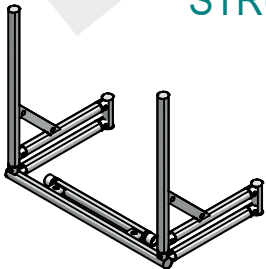

4
INPUT
CONVEYOR

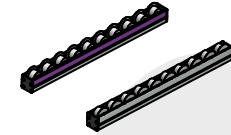

5
OUTPUT
CONVEYOR

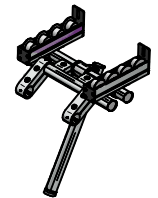

PROJECT NAME:	CS-00011206_KARAKURI USTAKING.asm
DESIGN BY:	EdderAcuñaMorales/14/2023
DRAWING BY:	MSANDOVAL 6/5/2023
CUSTOMER APPROVAL	

item
MEXICO

SystemSolid Edge



CUSTOMER:	MABE
DWG. NAME:	CS-00011206_KARAKURI USTAKING_Draft
SOLUTION:	REV.:
Unless otherwise specified, all measures are in mm	
PAGE: 3	

1 FRAME

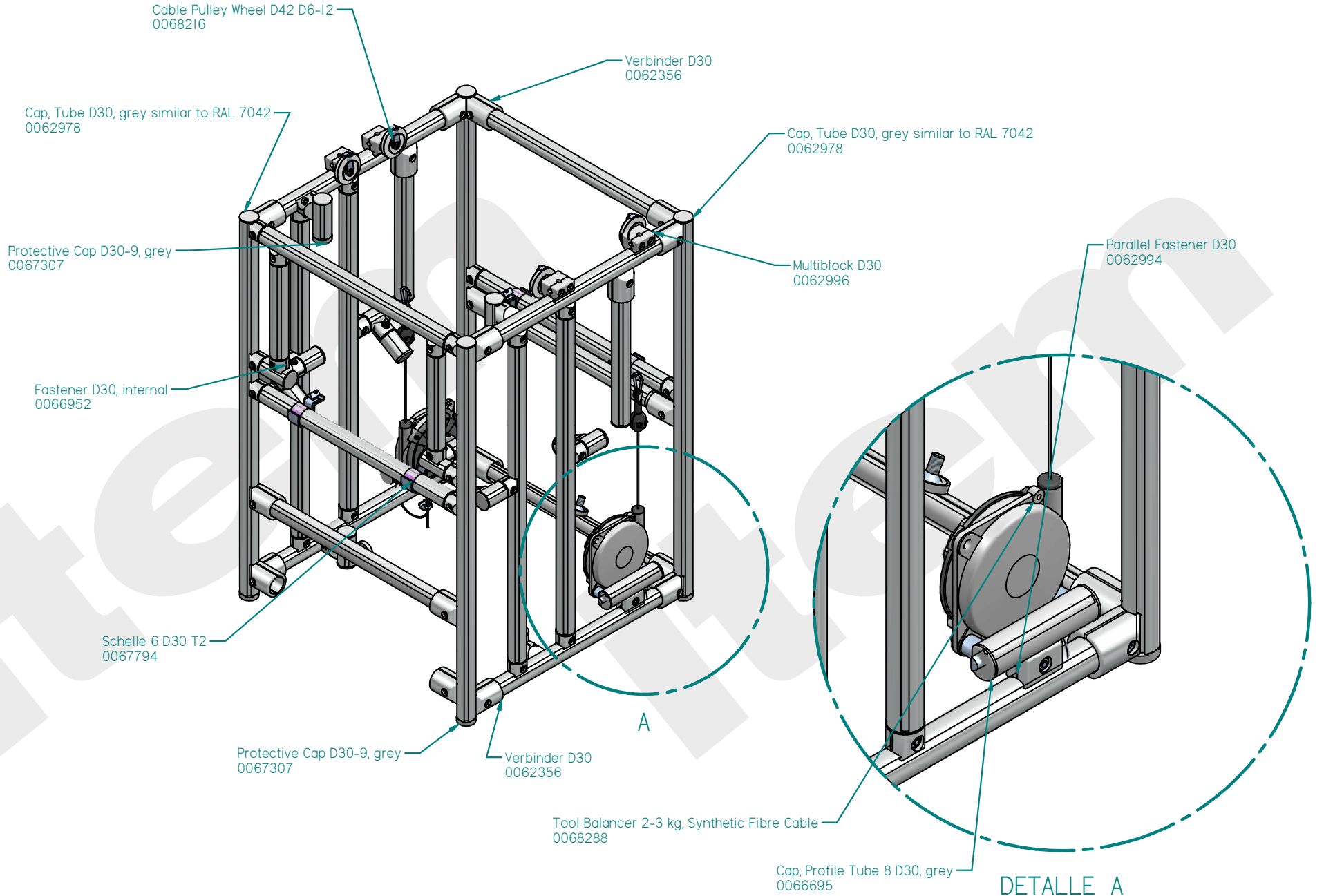

PROJECT NAME:	CS-00011206_KARAKURI USTAKING.asm
DESIGN BY:	EdderAcuñaMorales/14/2023
DRAWING BY:	MSANDOVAL 6/5/2023
CUSTOMER APPROVAL	

item
MEXICO

SystemSolid Edge

CUSTOMER:	MABE
DWG. NAME:	CS-00011206_KARAKURI USTAKING_Draft
SOLUTION:	
REV.:	
Unless otherwise specified, all measures are in mm	
PAGE:	4

1 FRAME

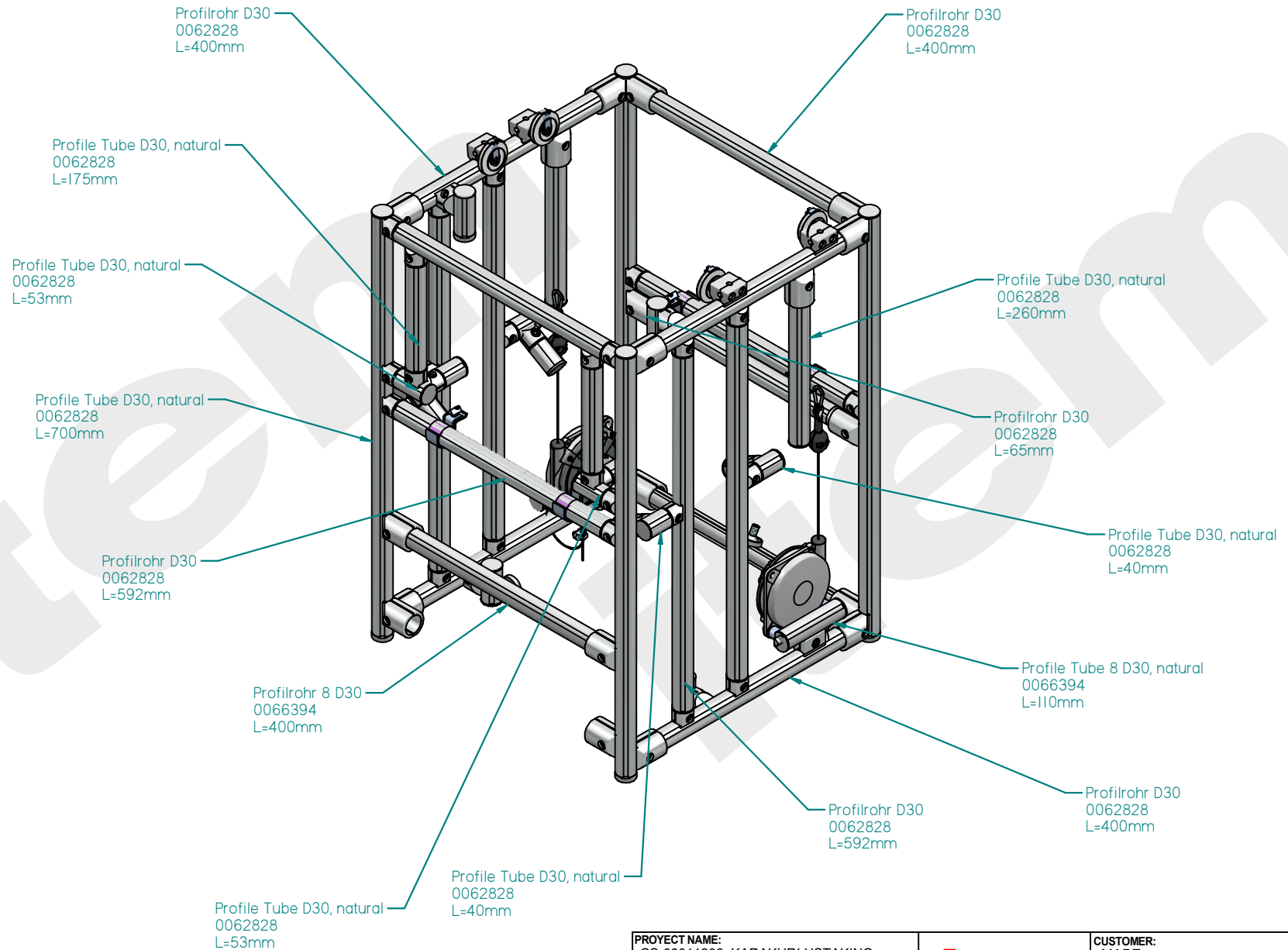

PROJECT NAME:	CS-00011206_KARAKURI USTAKING.asm
DESIGN BY:	EdderAcuñaMorales/14/2023
DRAWING BY:	MSANDOVAL 6/5/2023
CUSTOMER APPROVAL	

item
MEXICO

SystemSolid Edge



CUSTOMER:	MABE
DWG. NAME:	CS-00011206_KARAKURI USTAKING_Draft
SOLUTION:	
REV.:	
Unless otherwise specified, all measures are in mm	
PAGE:	5

1 FRAME

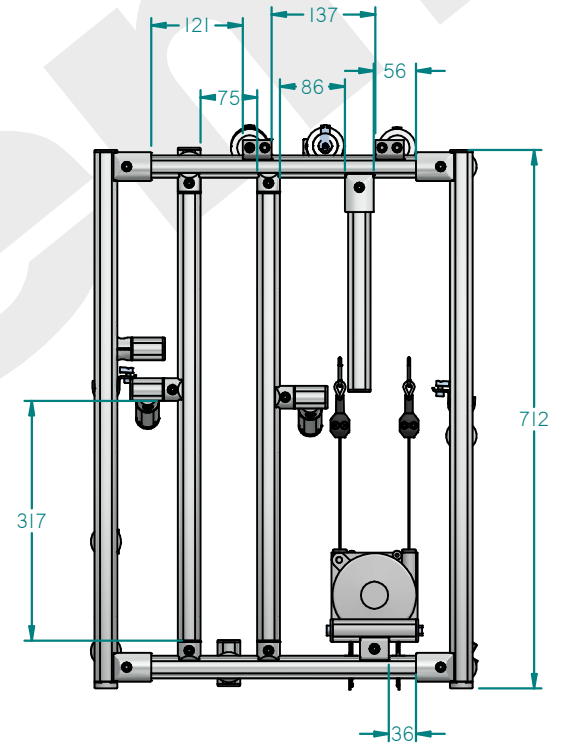
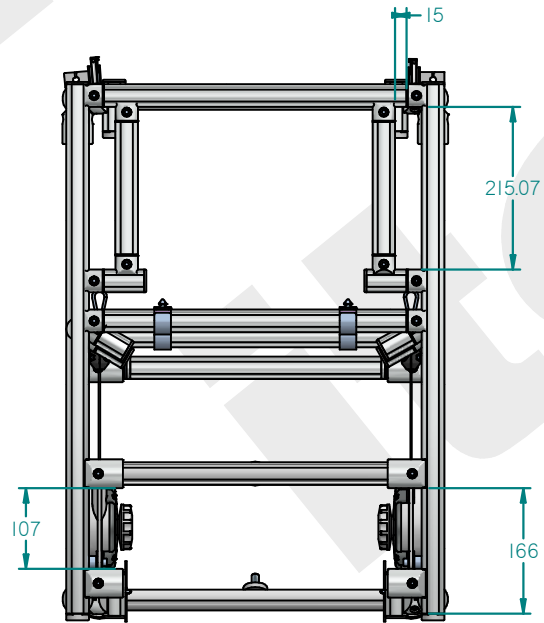
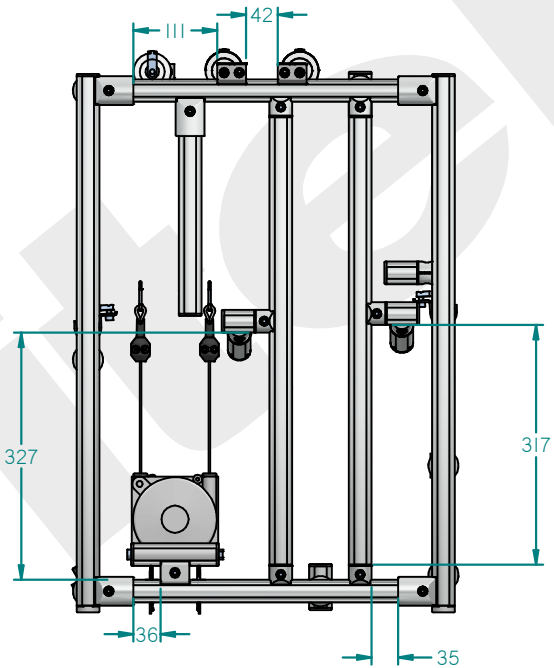
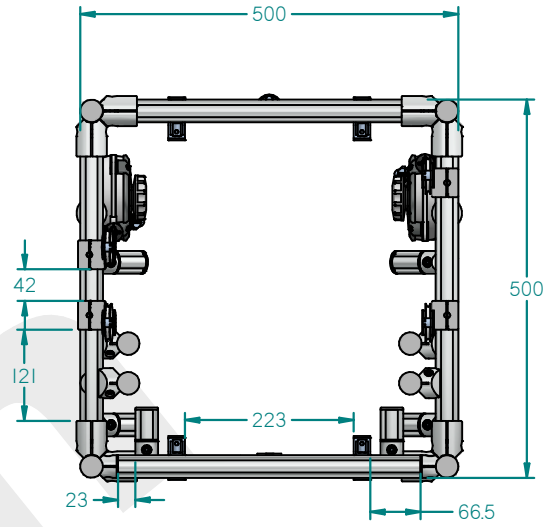

PROJECT NAME:	CS-00011206_KARAKURI USTAKING.asm
DESIGN BY:	EdderAcuñaMorales/14/2023
DRAWING BY:	MSANDOVAL 6/5/2023
CUSTOMER APPROVAL	

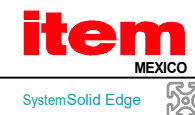

CUSTOMER:	MABE
DWG. NAME:	CS-00011206_KARAKURI USTAKING_Draft
SOLUTION:	
REV.:	
Unless otherwise specified, all measures are in mm	
PAGE:	6

2 BASKET

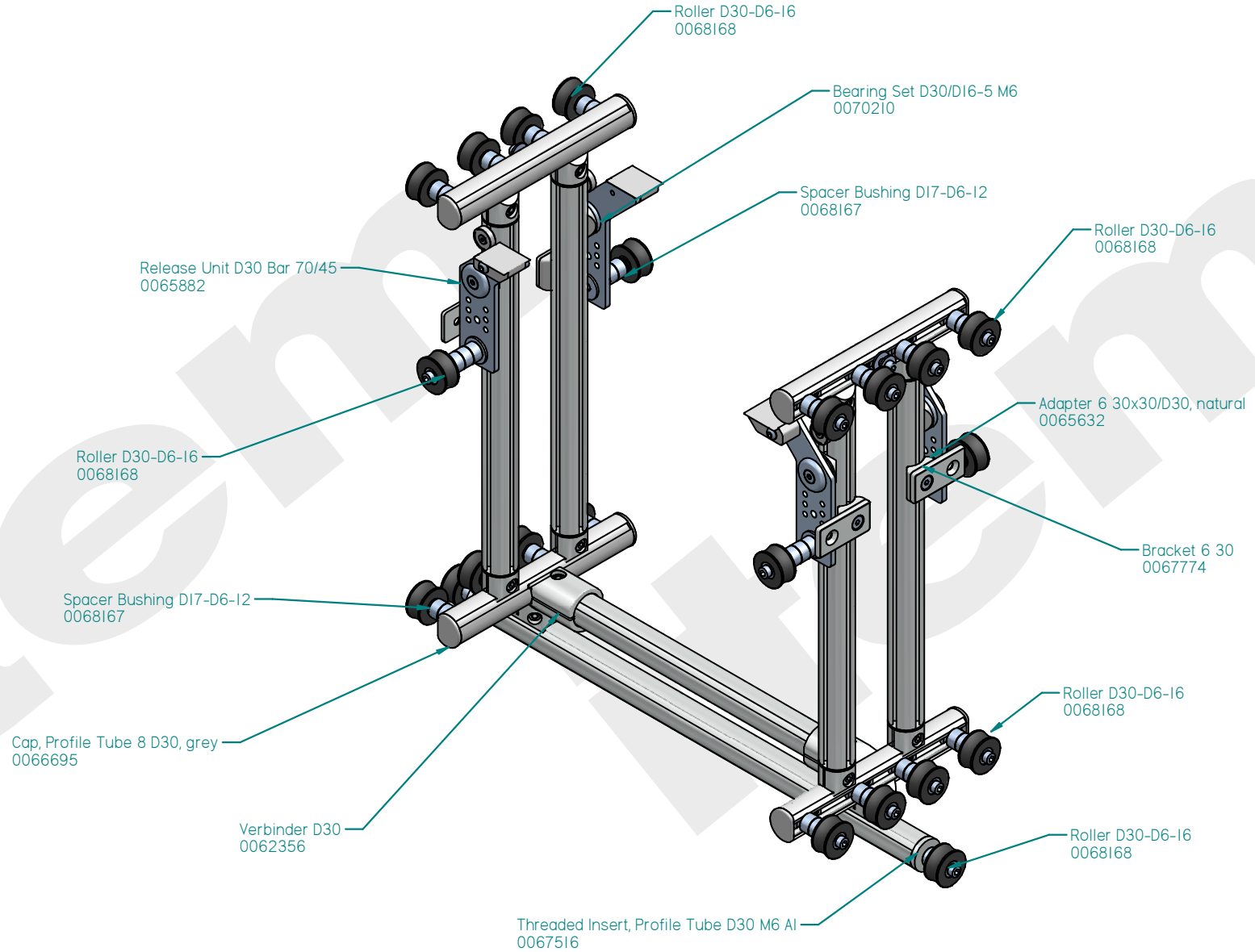

PROJECT NAME:	CS-00011206_KARAKURI USTAKING.asm
DESIGN BY:	EdderAcuñaMorales/14/2023
DRAWING BY:	MSANDOVAL 6/5/2023
CUSTOMER APPROVAL	

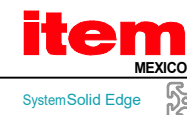

CUSTOMER:	MABE
DWG. NAME:	CS-00011206_KARAKURI USTAKING_Draft
SOLUTION:	
REV.:	
Unless otherwise specified, all measures are in mm	
PAGE:	7

2 BASKET

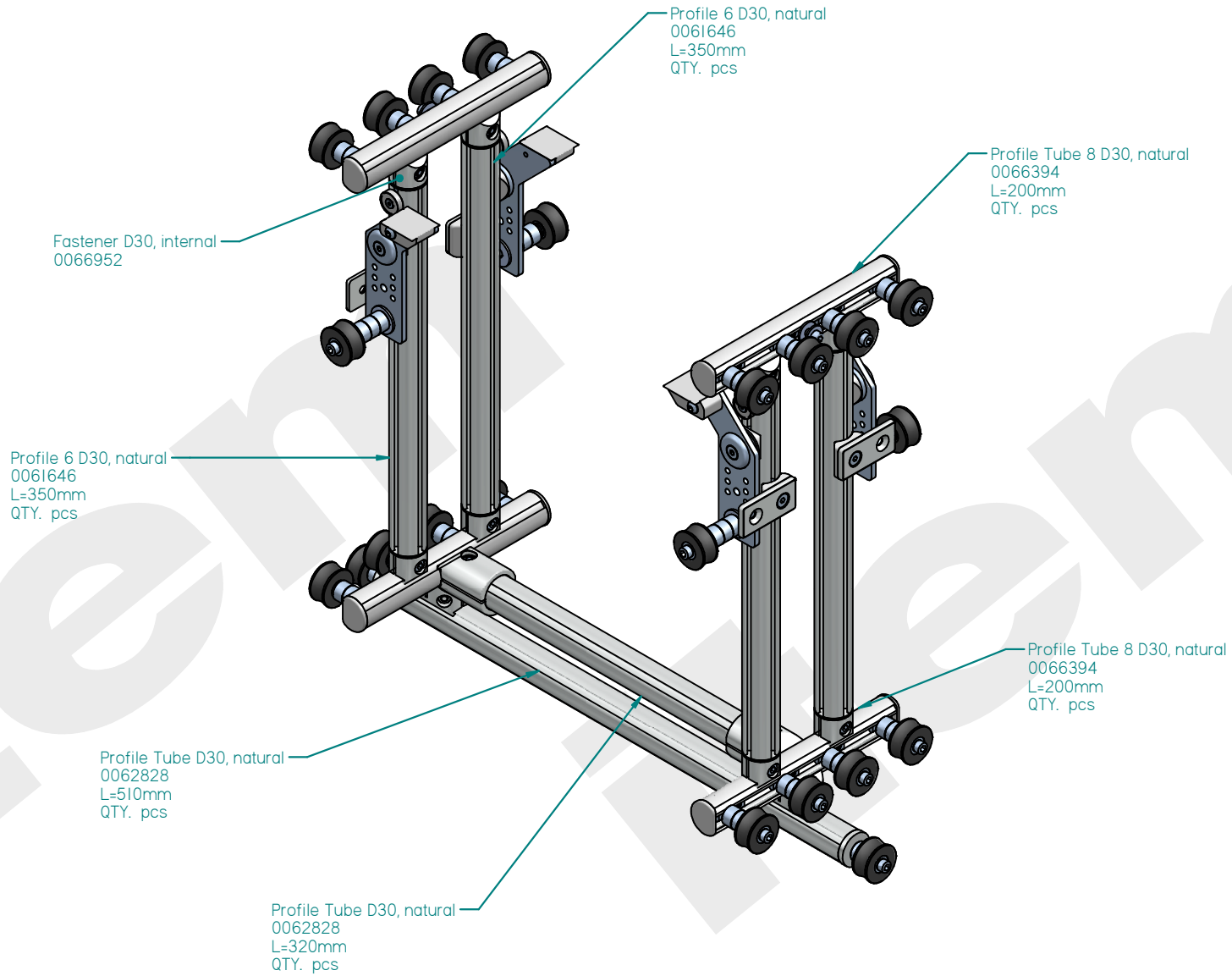

PROYECT NAME: CS-00011206_KARAKURI USTAKING.asm	
DESIGN BY:	EdderAcuñaMorales/14/2023
DRAWING BY:	MSANDOVAL 6/5/2023
CUSTOMER APPROVAL	



SystemSolid Edge



CUSTOMER: MABE	
DWG. NAME:	CS-00011206_KARAKURI USTAKING_Draft
SOLUTION:	REV.:
Unless otherwise specified, all measures are in mm	
PAGE: 8	

2 BASKET

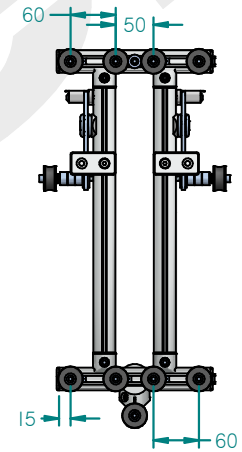
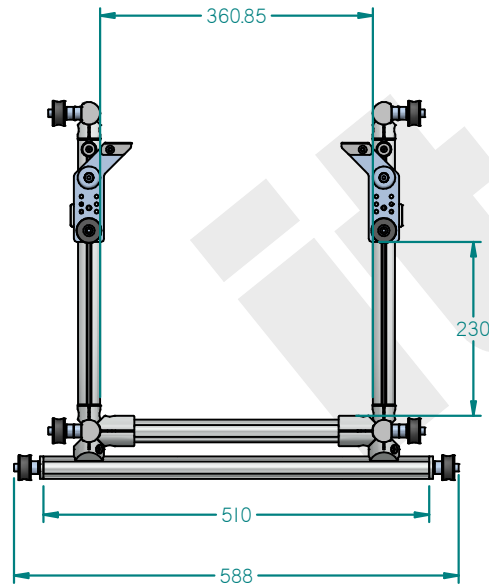
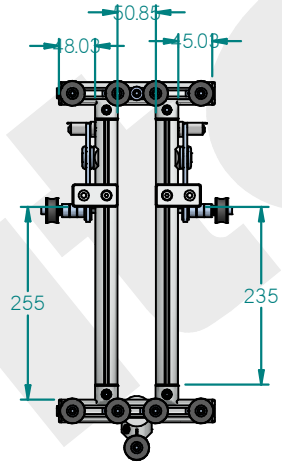
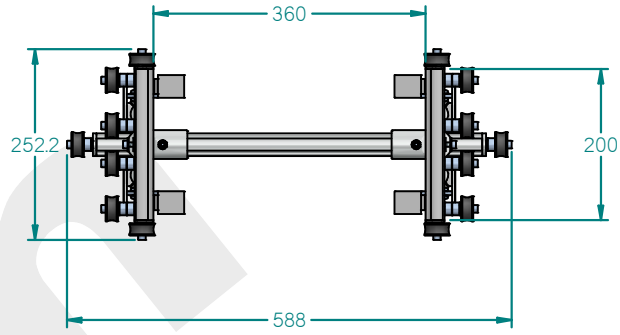

PROJECT NAME:	CS-00011206_KARAKURI USTAKING.asm
DESIGN BY:	EdderAcuñaMorales/14/2023
DRAWING BY:	MSANDOVAL 6/5/2023
CUSTOMER APPROVAL	

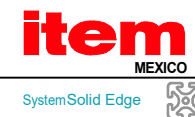

CUSTOMER:	MABE
DWG. NAME:	CS-00011206_KARAKURI USTAKING_Draft
SOLUTION:	
REV.:	
Unless otherwise specified, all measures are in mm	
PAGE:	9

3 FRONT STRUCTURE

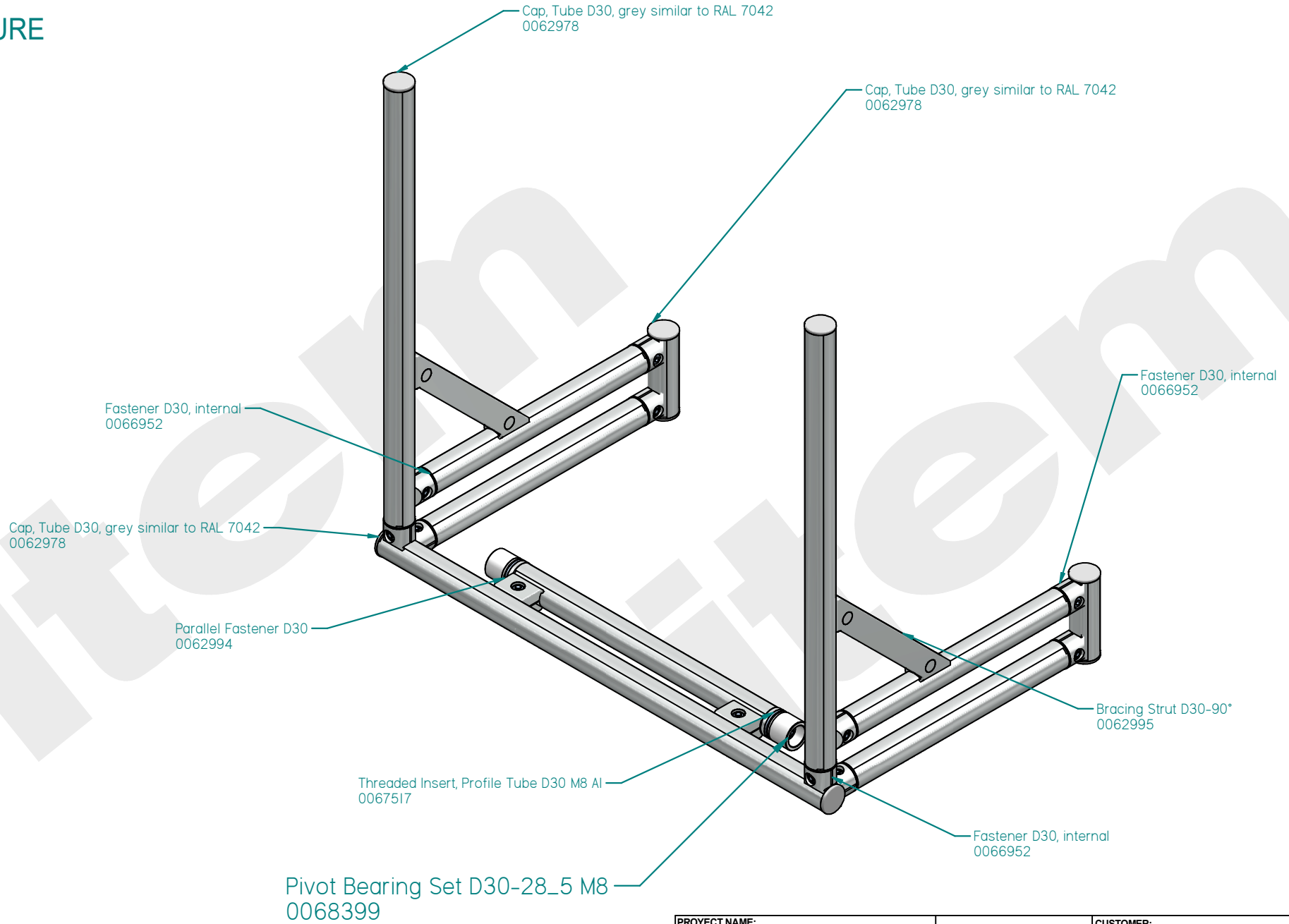

PROJECT NAME: CS-00011206_KARAKURI USTAKING.asm		item MEXICO	CUSTOMER: MABE	
DESIGN BY: EdderAcuñaMorales/14/2023	DRAWING BY: MSANDOVAL 6/5/2023		DWG. NAME: CS-00011206_KARAKURI USTAKING_Draft	REV.:
CUSTOMER APPROVAL		SystemSolid Edge	Unless otherwise specified, all measures are in mm	PAGE: 10

3 FRONT STRUCTURE

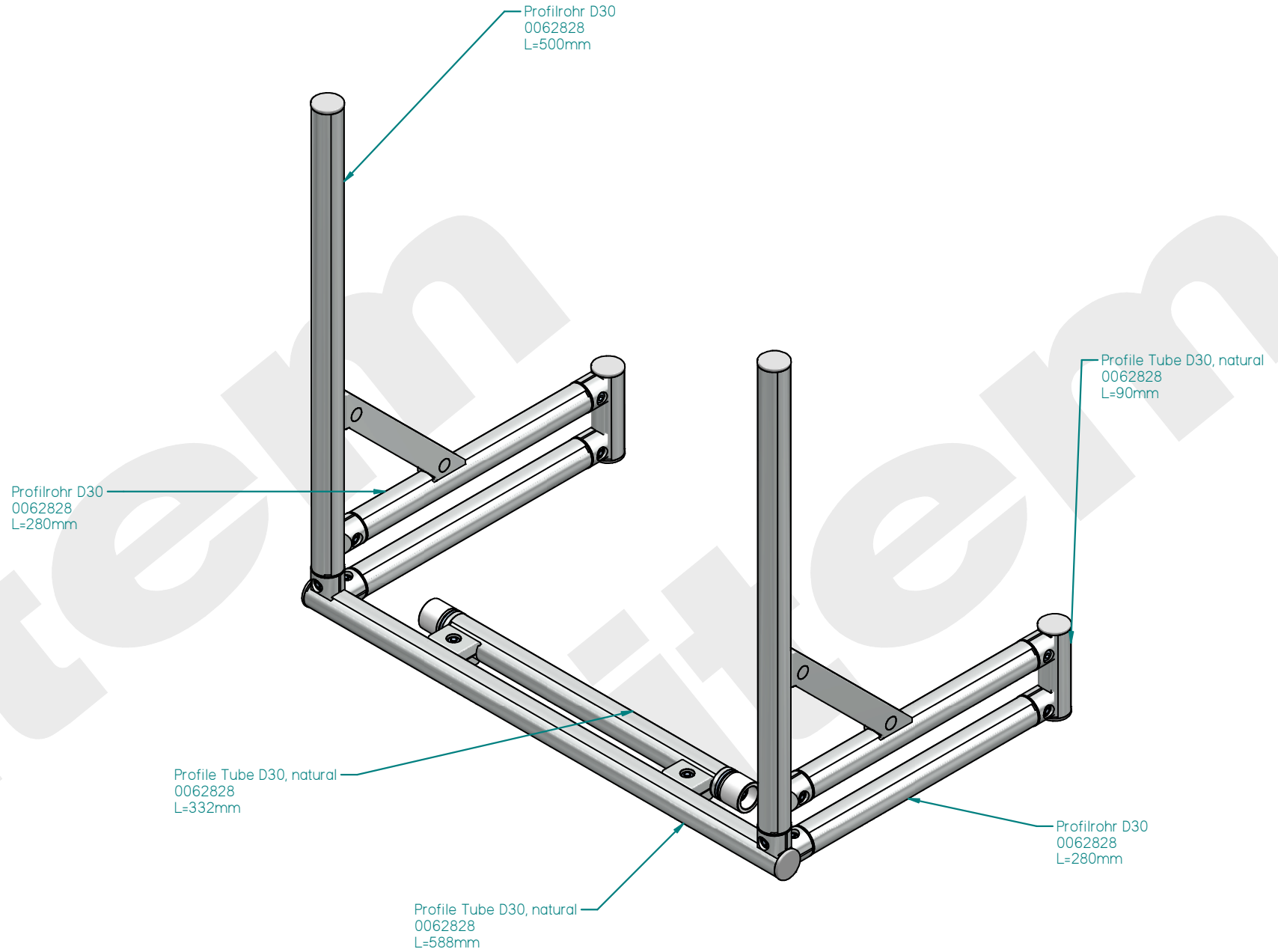

PROJECT NAME:	CS-00011206_KARAKURI USTAKING.asm	
DESIGN BY:	EdderAcuñaMorales	5/14/2023
DRAWING BY:	MSANDOVAL	6/5/2023
CUSTOMER APPROVAL		

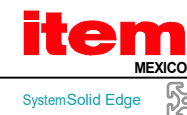

CUSTOMER:	MABE	
DWG. NAME:	CS-00011206_KARAKURI USTAKING_Draft	
SOLUTION:		REV.:
Unless otherwise specified, all measures are in mm		PAGE: 11

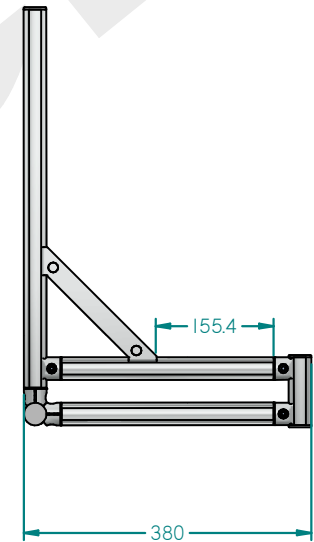
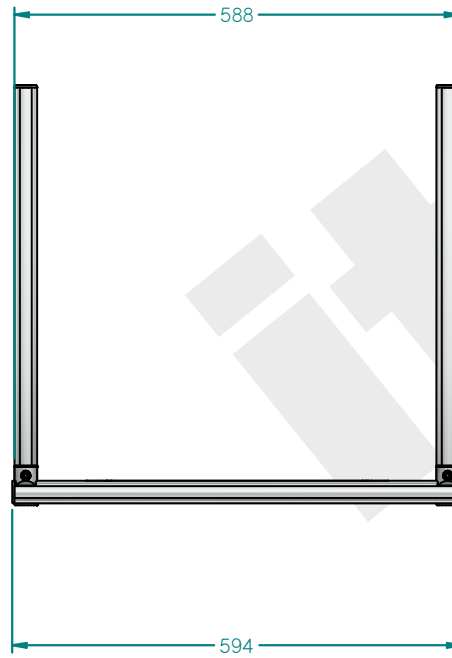
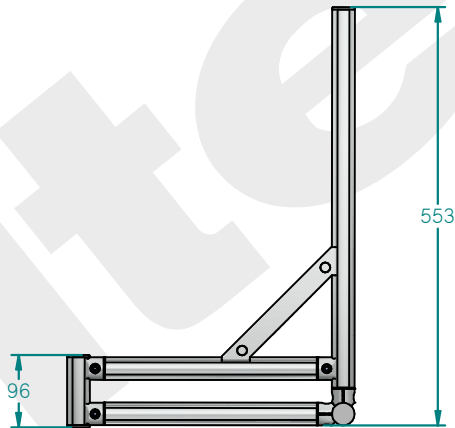
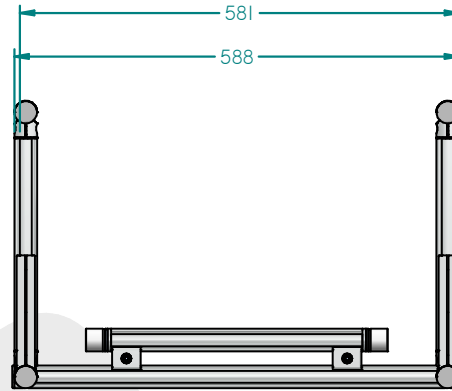

PROJECT NAME:	CS-00011206_KARAKURI USTAKING.asm	
DESIGN BY:	EdderAcuñaMoj	5/14/2023
DRAWING BY:	MSANDOVAL	6/5/2023
CUSTOMER APPROVAL		

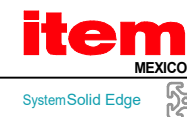

CUSTOMER:	MABE	
DWG. NAME:	CS-00011206_KARAKURI USTAKING_Draft	
SOLUTION:		REV.:
Unless otherwise specified, all measures are in mm		PAGE: 12

4 INPUT CONVEYOR

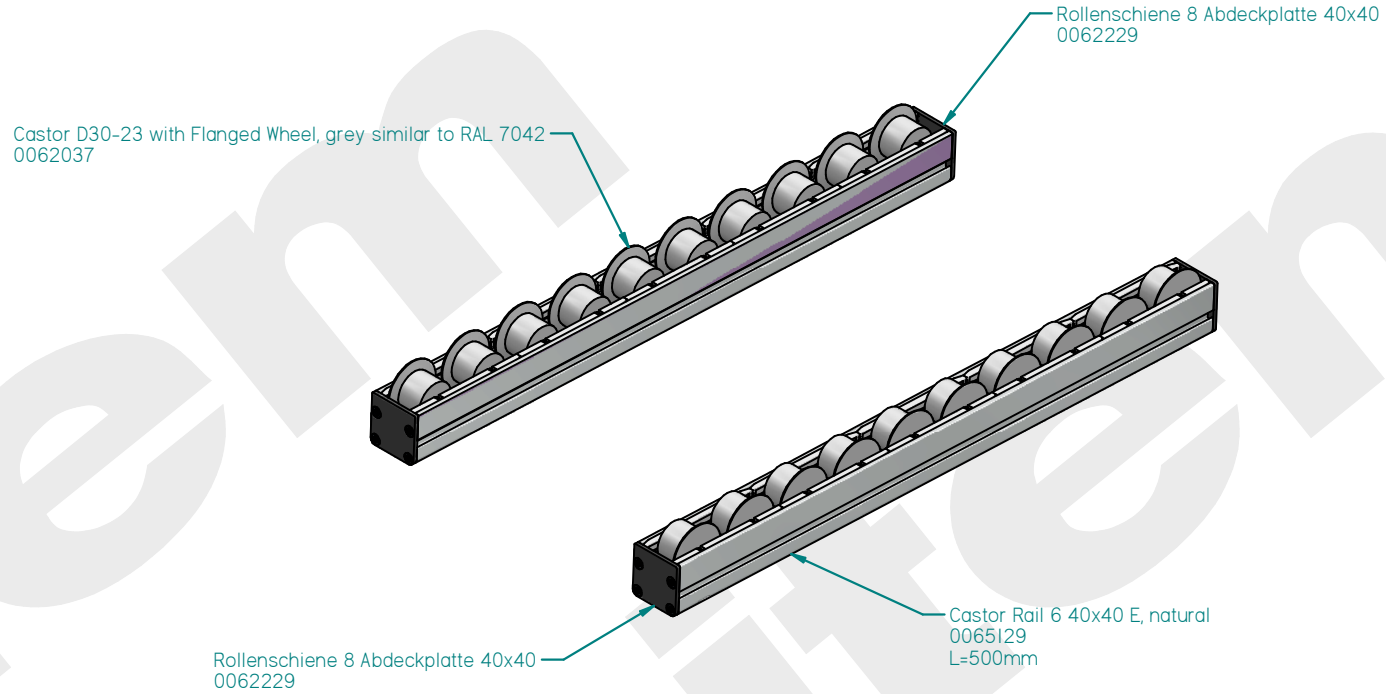

PROYECT NAME: CS-00011206_KARAKURI USTAKING.asm	
DESIGN BY:	EdderAcuñaMojas/14/2023
DRAWING BY:	MSANDOVAL 6/5/2023
CUSTOMER APPROVAL	

item
MEXICO

SystemSolid Edge 

CUSTOMER: MABE	
DWG. NAME:	CS-00011206_KARAKURI USTAKING_Draft
SOLUTION:	REV.:
Unless otherwise specified, all measures are in mm	
PAGE: 13	

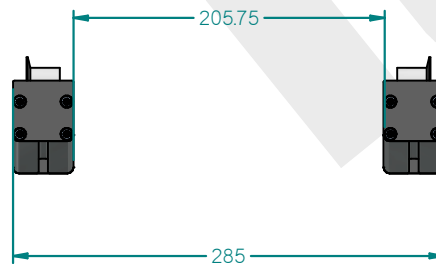
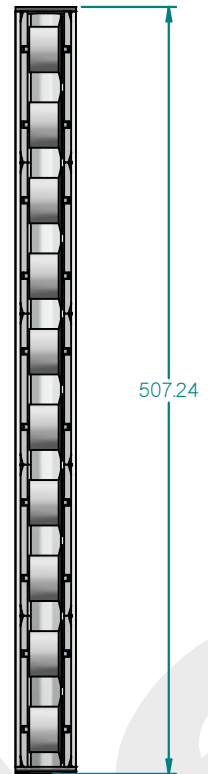
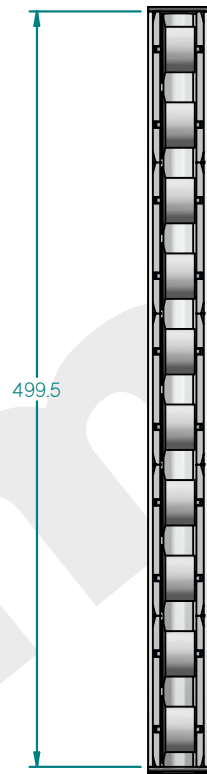

PROJECT NAME: CS-00011206_KARAKURI USTAKING.asm	
DESIGN BY:	EdderAcuñaMorales/14/2023
DRAWING BY:	MSANDOVAL 6/5/2023
CUSTOMER APPROVAL	

item
MEXICO

SystemSolid Edge



CUSTOMER: MABE	
DWG. NAME:	CS-00011206_KARAKURI USTAKING_Draft
SOLUTION:	REV.:
Unless otherwise specified, all measures are in mm	
PAGE: 14	

5 OUTPUT CONVEYOR

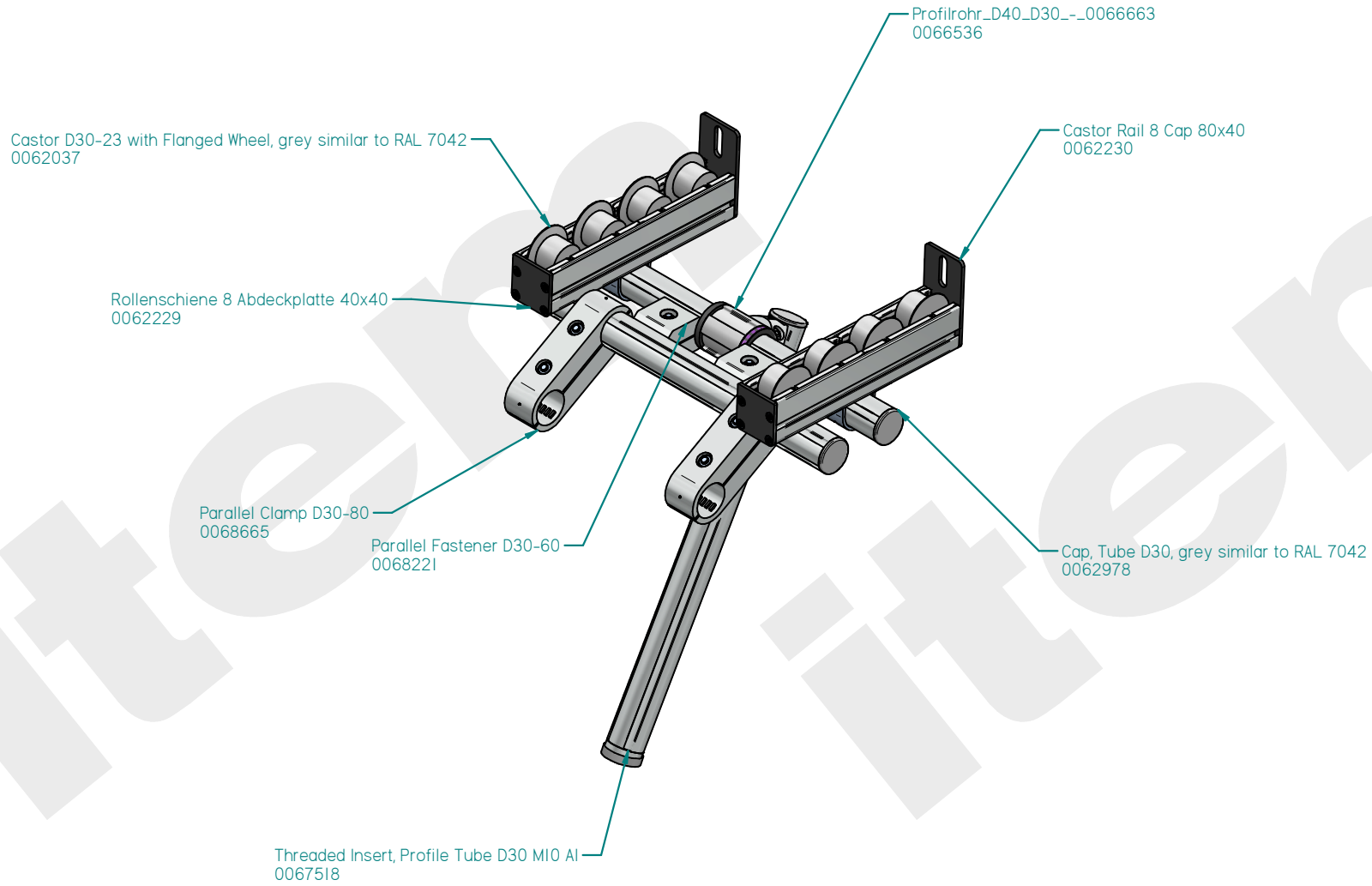

PROJECT NAME: CS-00011206_KARAKURI USTAKING.asm	
DESIGN BY:	EdderAcuñaMorales/14/2023
DRAWING BY:	MSANDOVAL 6/5/2023
CUSTOMER APPROVAL	

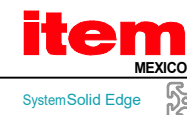

CUSTOMER: MABE	
DWG. NAME:	CS-00011206_KARAKURI USTAKING_Draft
SOLUTION:	REV.:
Unless otherwise specified, all measures are in mm	
PAGE: 15	

5
OUTPUT
CONVEYOR

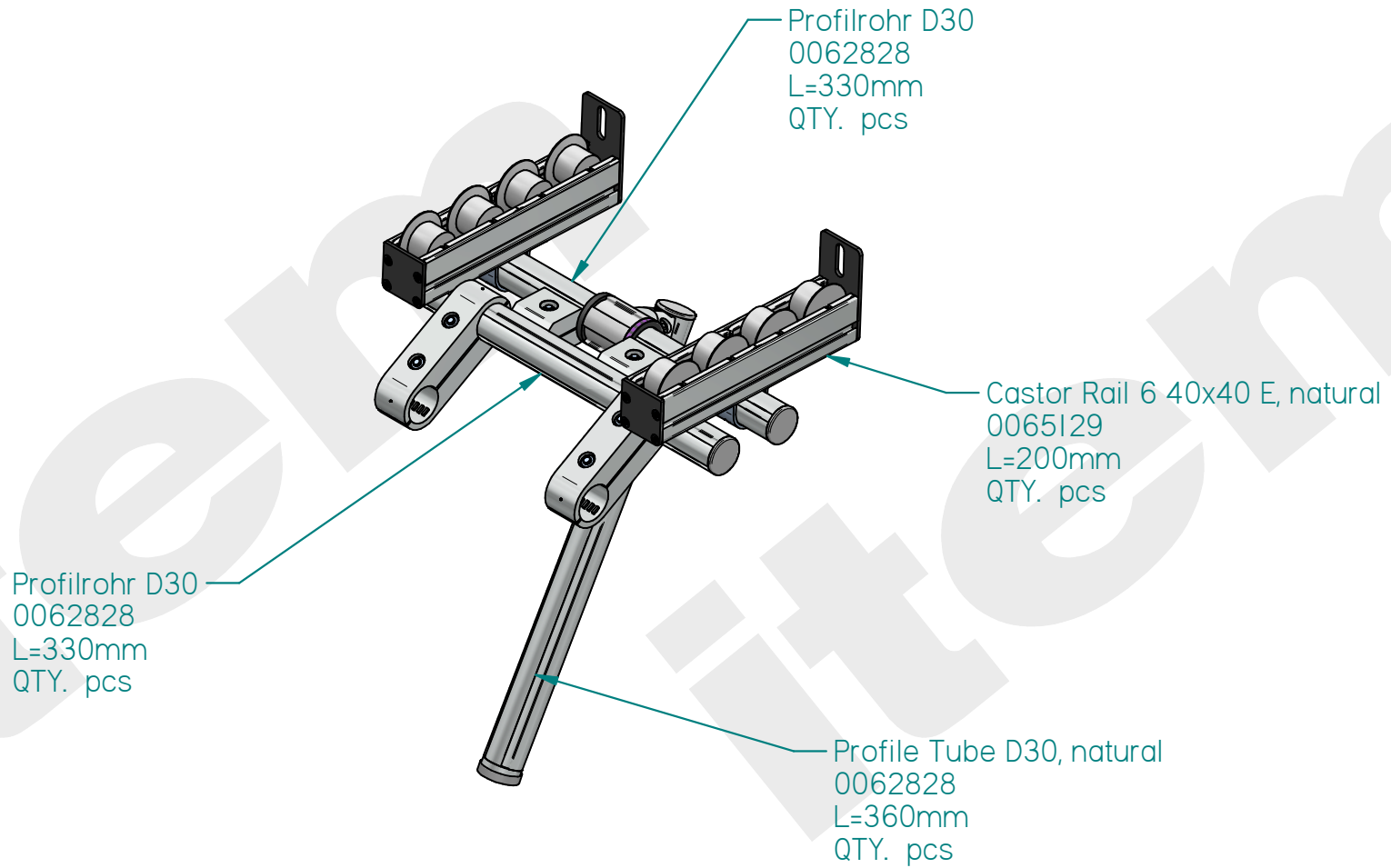

PROJECT NAME: CS-00011206_KARAKURI USTAKING.asm	
DESIGN BY:	EdderAcuñaMojas/14/2023
DRAWING BY:	MSANDOVAL 6/5/2023
CUSTOMER APPROVAL	

item
MEXICO

SystemSolid Edge



CUSTOMER: MABE	
DWG. NAME:	CS-00011206_KARAKURI USTAKING_Draft
SOLUTION:	REV.:
Unless otherwise specified, all measures are in mm	
PAGE: 16	

5 OUTPUT CONVEYOR

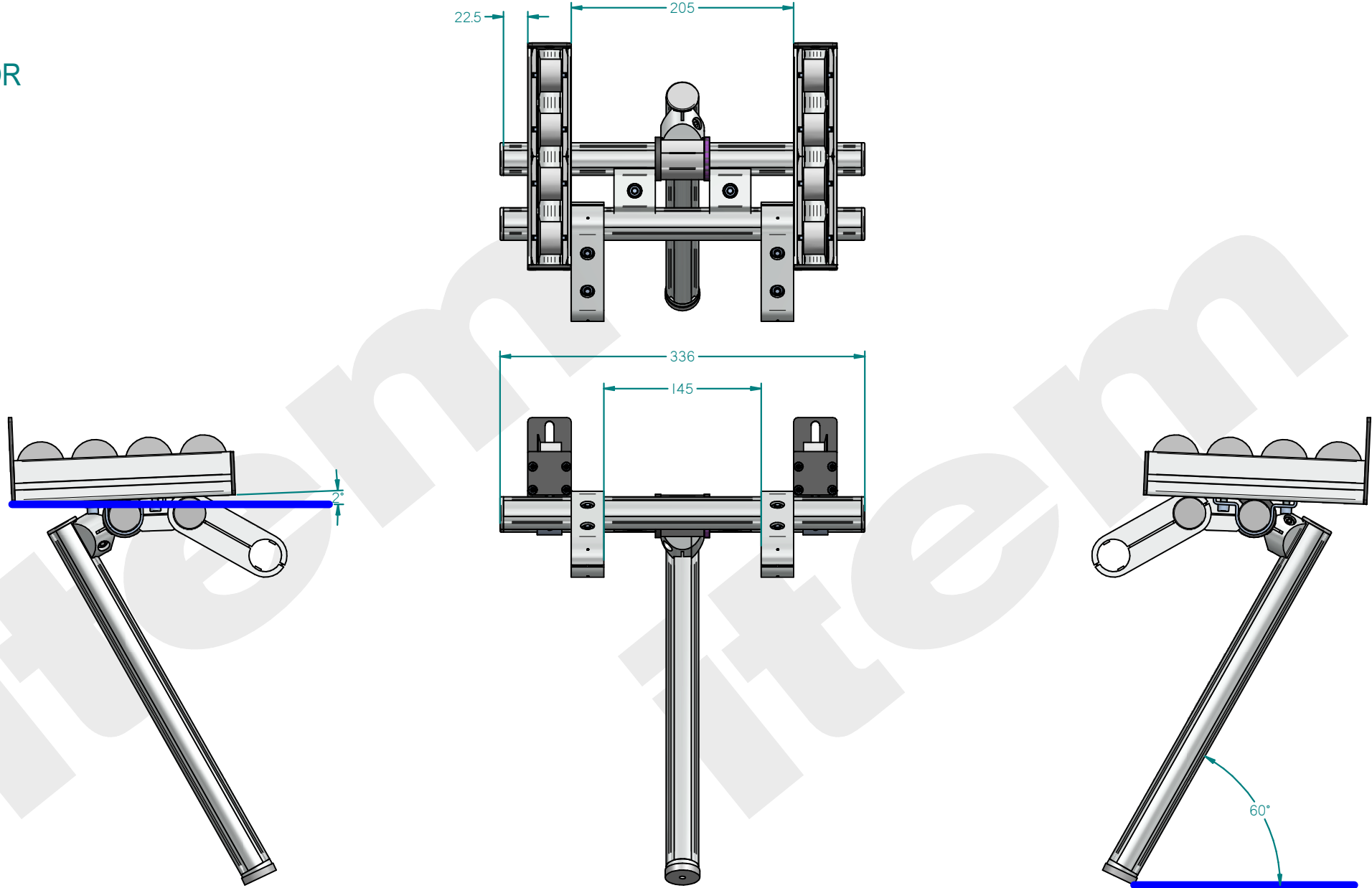

PROJECT NAME:	CS-00011206_KARAKURI USTAKING.asm
DESIGN BY:	EdderAcuñaMorales/14/2023
DRAWING BY:	MSANDOVAL 6/5/2023
CUSTOMER APPROVAL	

item
MEXICO

SystemSolid Edge 

CUSTOMER:	MABE
DWG. NAME:	CS-00011206_KARAKURI USTAKING_Draft
SOLUTION:	REV.:
Unless otherwise specified, all measures are in mm	
PAGE: 17	

ASSEMBLY

To fix the conveyors to the frame, we are going to use the Bracket to connect with the conveyor rail.

T-slots must be inside of the profile.



DETALLE B

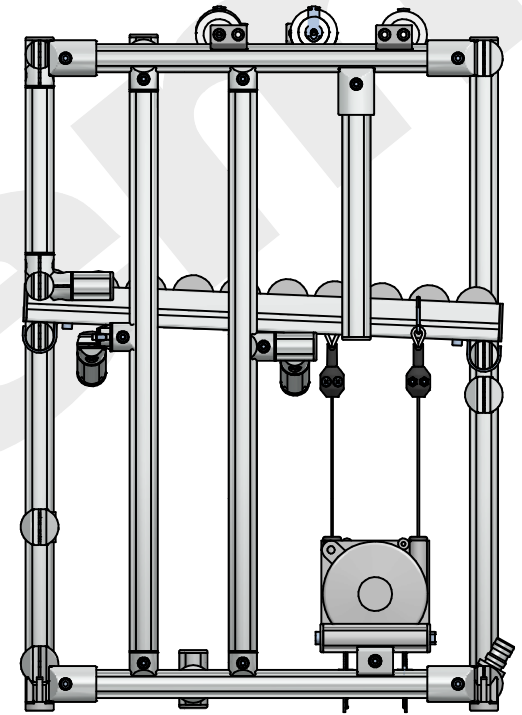
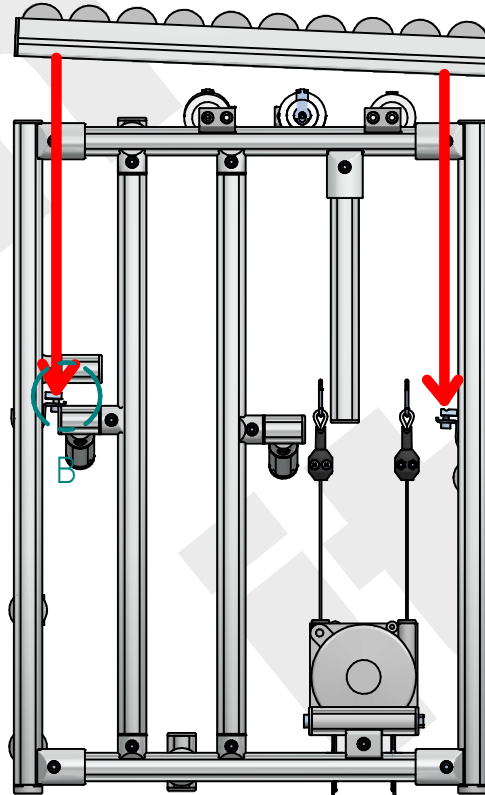

PROJECT NAME:	CS-00011206_KARAKURI USTAKING.asm	
DESIGN BY:	EdderAcuñaMoj	5/14/2023
DRAWING BY:	MSANDOVAL	6/5/2023
CUSTOMER APPROVAL		



SystemSolid Edge

CUSTOMER:	MABE	
DWG. NAME:	CS-00011206_KARAKURI USTAKING_Draft	
SOLUTION:		REV.:
Unless otherwise specified, all measures are in mm		
		PAGE: 18

ASSEMBLY

To add the output conveyors we should connect the the neodyne magnet to the threaded insert, and both of the parallel clamps on the pivot profile on the frame.

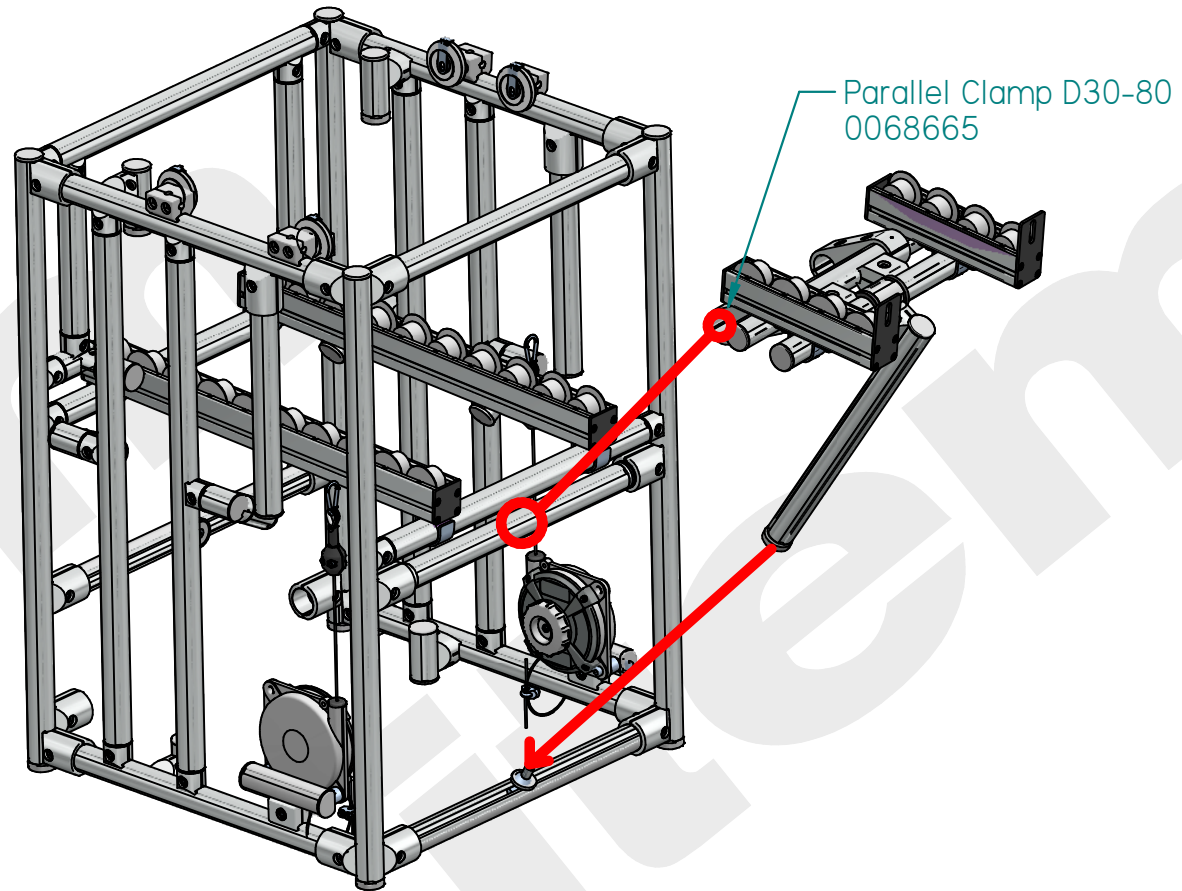

PROYECT NAME:	CS-00011206_KARAKURI USTAKING.asm
DESIGN BY:	EdderAcuñaMojón/14/2023
DRAWING BY:	MSANDOVAL 6/5/2023
CUSTOMER APPROVAL	

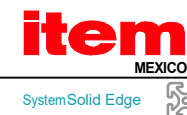

CUSTOMER:	MABE
DWG. NAME:	CS-00011206_KARAKURI USTAKING_Draft
SOLUTION:	
REV.:	
Unless otherwise specified, all measures are in mm	
PAGE:	19

ASSEMBLY

For mounting the basket is necessary, remove the top rollers and after assembly the two structures, the profiles should be assembled again.

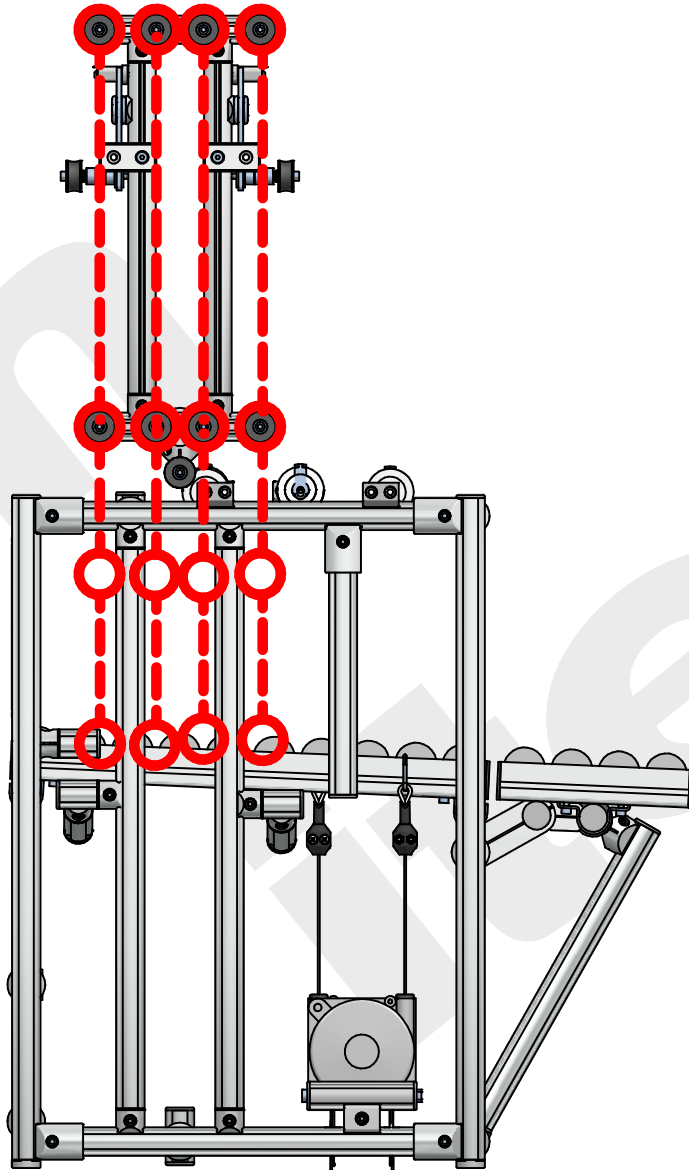

PROYECT NAME:	CS-00011206_KARAKURI USTAKING.asm
DESIGN BY:	EdderAcuñaMorales/14/2023
DRAWING BY:	MSANDOVAL 6/5/2023
CUSTOMER APPROVAL	

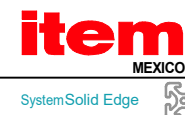

CUSTOMER:	MABE
DWG. NAME:	CS-00011206_KARAKURI USTAKING_Draft
SOLUTION:	
REV.:	
Unless otherwise specified, all measures are in mm	
PAGE:	20

ASSEMBLY

Connect the tool balancer cable to the basket, but this cable should be through the pulley, remember tension can be adjusted on the tool balancer.

When we put together these sub-assemblies we should keep in mind, that the 4 rollers should be aligned to the D30 profiles in both sides.

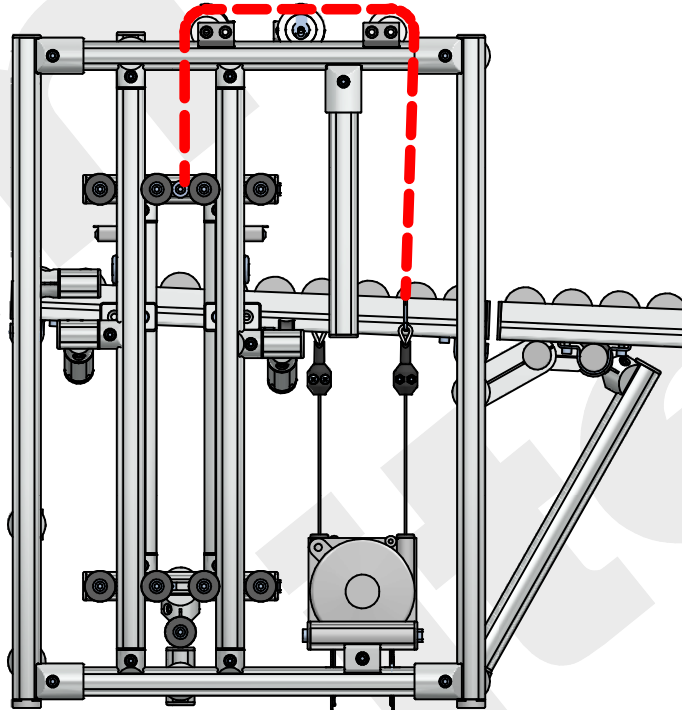

PROJECT NAME:	CS-00011206_KARAKURI USTAKING.asm
DESIGN BY:	EdderAcuñaMojas/14/2023
DRAWING BY:	MSANDOVAL 6/5/2023
CUSTOMER APPROVAL	

item
MEXICO

SystemSolid Edge



CUSTOMER:	MABE
DWG. NAME:	CS-00011206_KARAKURI USTAKING_Draft
SOLUTION:	
REV.:	
Unless otherwise specified, all measures are in mm	
PAGE:	21

ASSEMBLY

To join the Front Structure to the assembly, we are going to use the pivot bearings at the front of the assembly, to join the Frame to it.

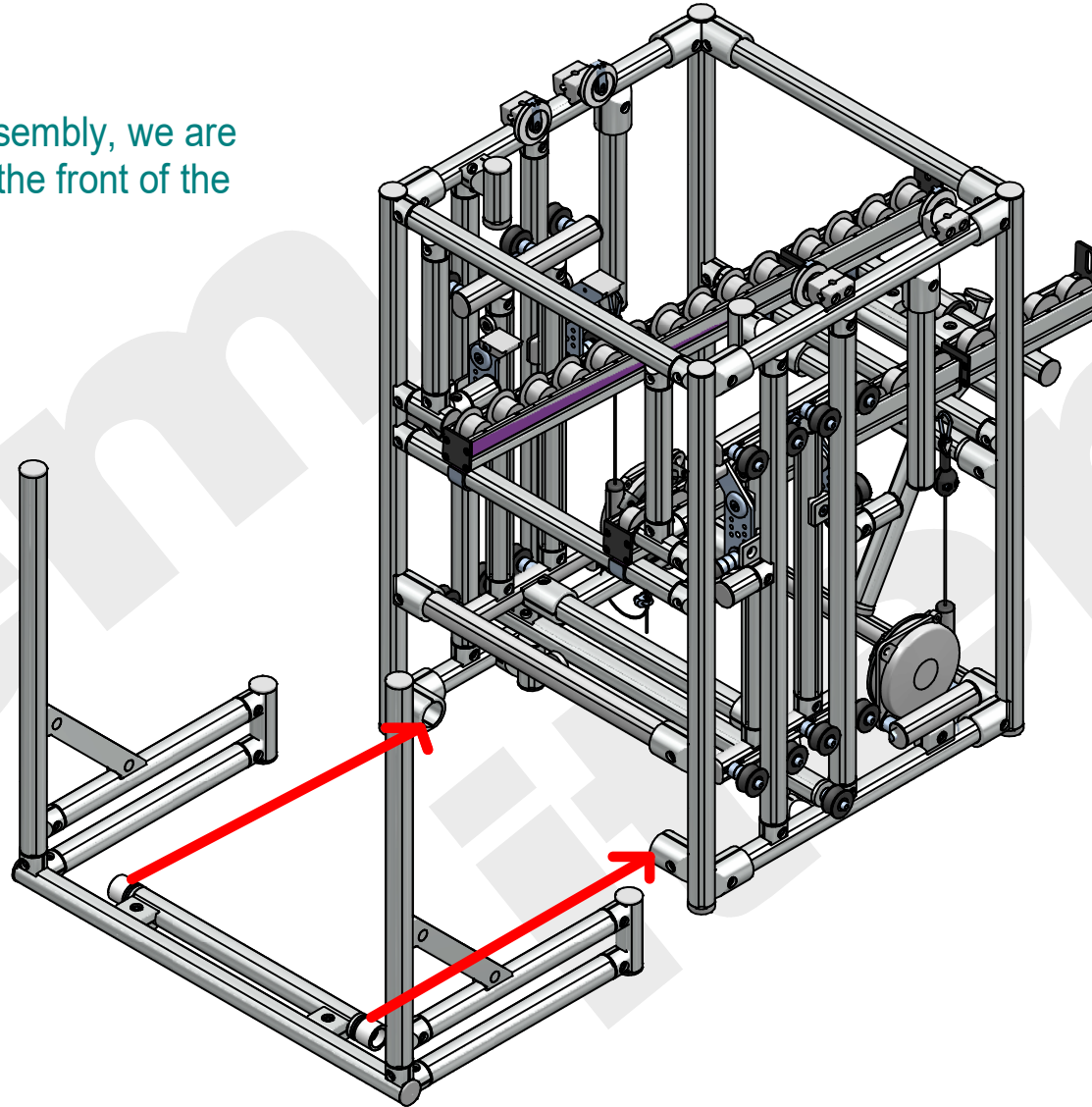

PROJECT NAME:	CS-00011206_KARAKURI_USTAKING.asm
DESIGN BY:	EderAcuñaMorales/14/2023
DRAWING BY:	MSANDOVAL 6/5/2023
CUSTOMER APPROVAL	

item
MEXICO

SystemSolid Edge 

CUSTOMER:	MABE
DWG. NAME:	CS-00011206_KARAKURI_USTAKING_Draft
SOLUTION:	
REV.:	
Unless otherwise specified, all measures are in mm	
PAGE:	22

ASSEMBLY

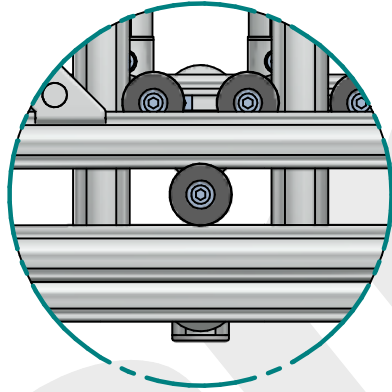

DETALLE C

We should guarantee that the roller of the Box Holder is between the two side D30 Tubes.

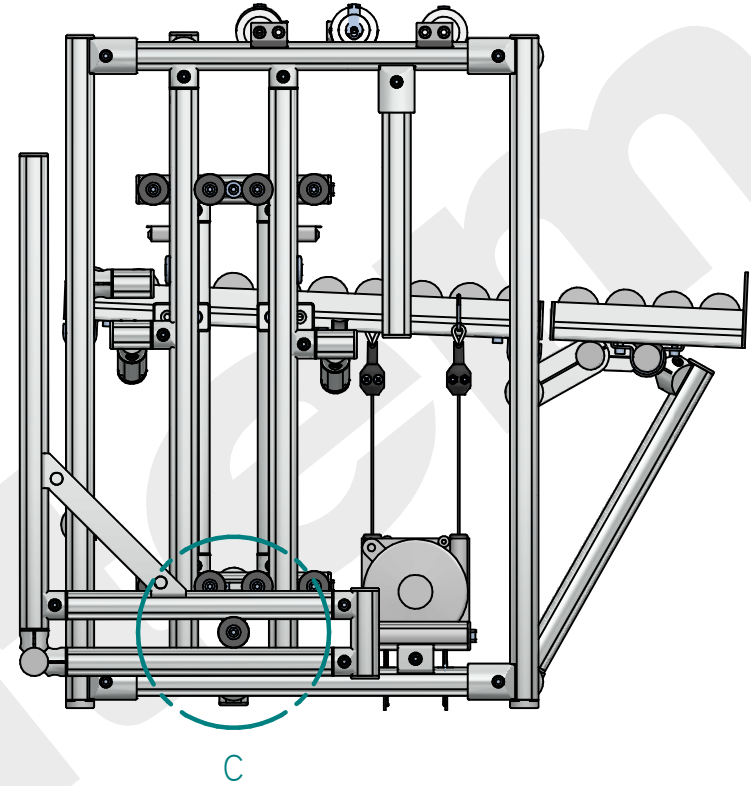

PROJECT NAME:	CS-00011206_KARAKURI USTAKING.asm
DESIGN BY:	EdderAcuñaMorales/14/2023
DRAWING BY:	MSANDOVAL 6/5/2023
CUSTOMER APPROVAL	

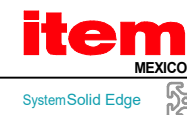

CUSTOMER:	MABE
DWG. NAME:	CS-00011206_KARAKURI USTAKING_Draft
SOLUTION:	
REV.:	
Unless otherwise specified, all measures are in mm	
PAGE:	23

Great job!
You finished the assembly, at this moment you only need to check the flow of your box or package and adjust if it's necessary.
Thanks a lot!

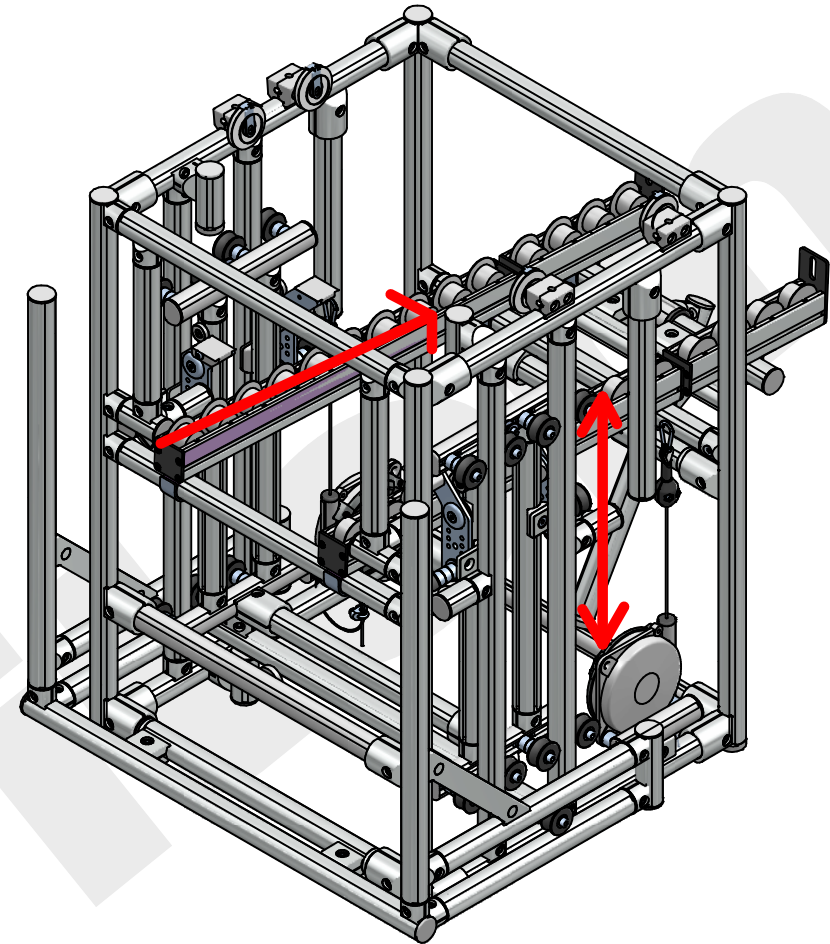

PROYECT NAME: CS-00011206_KARAKURI USTAKING.asm	item MEXICO	CUSTOMER: MABE	
DESIGN BY: EdderAcuñaMorales/14/2023		DWG. NAME: CS-00011206_KARAKURI USTAKING_Draft	
DRAWING BY: MSANDOVAL 6/5/2023	SystemSolid Edge 	SOLUTION:	REV.:
CUSTOMER APPROVAL		Unless otherwise specified, all measures are in mm	PAGE: 24